

Union Pacific Railroad Company 2012 Standards Manual

Fiber Optic Engineering, Construction and Maintenance Standards



These standards are developed for fiber optic customer construction and associated work practices. To access this manual online visit Telecom/Fiber Optic/SAFT under the About Us section on www.up.com

Call Before You Dig: 1-800-336-9193



EXHIBIT A

UNION PACIFIC RAILROAD COMPANY

**Fiber Optics & Asset Utilization Group
1400 Douglas Street – Mail Stop 0640
Omaha, NE 68179**

ADMINISTRATION & CONSTRUCTION

CRAIG JOHNSTON
DIRECTOR FIBER OPTICS & ASSET UTILIZATION
MAIL STOP 0640
(402) 544-0574 C (402) 203-3292
CRAIGJOHNSTON@UP.COM

MIKE SHALLOW
SR. MANAGER FIBER OPTICS &
ASSET UTILIZATION
MAIL STOP 0640
(402) 544-0570 C (402) 290-9419
MIKESHALLOW@UP.COM

BOB GIERY
INFORMATION TECHNOLOGY
SYSTEMS CONSULTANT
MAIL STOP 0640
(402) 544-7425 C (402) 203-3719
RWGIERY@UP.COM

WIRELESS & PROPERTY MANAGEMENT

MIKE WALLMAN
ASSOCIATE SYSTEMS ENGINEER
MAIL STOP 0640
(402) 544-0577 C (402) 415-9877
MWALLMAN@UP.COM

THOMAS (TOM) MCGOVERN
PROJECT ENGINEER
MAIL STOP 0640
(402) 544-6090 C (402) 871-4005
TMCGOVERN@UP.COM

ENGINEERING

MICHAEL HEALD
SR. SYSTEMS ENGINEER
MAIL STOP 0640
(402) 544-3719 C (402) 740-2972
MCHEALD@UP.COM

PAUL PINO
PROJECT ENGINEER
MAIL STOP 0640
(402) 544-3582 C (402) 203-6021
PAULPINO@UP.COM

REGIONAL CONSTRUCTION COORDINATORS

MIKE ARGO
SOUTHERN LA, EASTERN TX
(402) 501-4568 C (832) 984-4406
MICHAELARGO@UP.COM

STEVE HEWITT
WA, OR, ID, MT, NORTHERN UT
(402) 501-4574 C (503) 708-9780
SAHEWITT@UP.COM

TIM NEUMAIER
AZ, NM
(520) 629-2148 C (520) 730-2257
TNEUMAIER@UP.COM

CLARENCE STYVAR
CO, WY, CENTRAL UT, WEST NE
(402)501-4571 C (402) 203-8732
CLSTYVAR@UP.COM

BILL J. WRIGHT
SOUTHERN TX, WESTERN TX
(402) 501-4575 C (314) 422-3217
BJWRIGHT@UP.COM

RON CHRISTENSEN
CENTRAL CA, NORTHERN CA
NORTHERN NV, NORTHERN UT
(402) 501-4053 C (530) 521-1045
RLCHRISI@UP.COM

JEFF OSTHUS
EAST NE, KS, MO, WESTERN IA
NORTHERN AR, NORTHERN OK
(402) 544-0559 C (402) 312-4999
JLOSTHUS@UP.COM

PHIL STEVENSON
SOUTHERN CA, SOUTHERN NV
(402) 501-4570 C (805) 312-6733
PASTEVENSON@UP.COM

DON (TOBY) TOBIAS
WI, IL, MN, EASTERN IA
(402) 501-4572 C (214) 707-1271
DJTOBIAS@UP.COM

STEVE WAITS
NORTHERN TX, NOUTHERN LA
SOUTHERN AR, SOUTHERN OK
(402) 501-4573 C (903) 235-9604
STEVEWAITS@UP.COM

TABLE OF CONTENTS

1	INITIAL CONTACT: ADMINISTRATIVE PROCEDURES.....	2
1.1	PROCEDURES FOR THE PLANNING OF NEW FIBER OPTIC CONSTRUCTION UTILIZING UNION PACIFIC RAILROAD COMPANY RIGHT-OF-WAY.....	2
2	ENGINEERING PROCESS	3
2.1	PLAN SUBMITTALS	3
2.2	NOTIFICATIONS:.....	3
3	PROJECT SAFETY, PLAN, DESIGN AND CONSTRUCTION OF FIBER OPTIC CABLE SYSTEMS.....	4
3.1	GENERAL PROJECT SAFETY	4
3.2	EMERGENCY RESPONSE PLAN	7
3.3	PERSONAL PROTECTIVE EQUIPMENT.....	8
3.4	TRAIN MOVEMENT AND WORKING NEAR TRACKS	9
3.5	RAILROAD FLAGGING/PROTECTION.....	10
3.6	PLANNING	11
3.7	DESIGN (General Requirements).....	13
3.8	DRAWINGS	16
3.9	CONSTRUCTION.....	18
3.10	GENERAL FIRE PREVENTION SAFETY and HOT WORK PROCESSES	28
3.11	WORK EQUIPMENT	29
3.12	WOKING NEAR POWER LINES.....	30
3.13	TRENCHES AND EXCAVATIONS	31
3.14	TRENCHLESS INSTALLATION OF FIBER SYSTEMS	31
3.15	HOUSEKEEPING	34
3.16	BRIDGES AND ABOVE GROUND INSTALLATIONS	35
3.17	WEATHER.....	36
3.18	REPEATER STATIONS (REGENS).....	36
4	DIG SAFELY – LOCATE ACCURATELY	38
5	DOCUMENTATION.....	39
5.1	DESIGNER REQUIREMENTS	39
6	MAINTENANCE.....	41
6.1	EMERGENCY MAINTENANCE.....	41
6.2	REGULAR MAINTENANCE	41
7	DEFINITIONS	43
8	ABBREVIATIONS.....	48
9	APPENDIX.....	49
9.1	List of Exhibits:.....	49
9.2	References:.....	49
10	INDEX.....	50
11	NOTES	51

1 INITIAL CONTACT: ADMINISTRATIVE PROCEDURES

1.1 PROCEDURES FOR THE PLANNING OF NEW FIBER OPTIC CONSTRUCTION UTILIZING UNION PACIFIC RAILROAD COMPANY RIGHT-OF-WAY.

- 1.1.1 Appropriate Union Pacific Railroad Company (Railroad) personnel (Refer to Exhibit A) will cooperatively work with the fiber optic company (FIBOCO) to generate the necessary documents to commence feasibility and preliminary engineering design of the proposed project.
- 1.1.2 Contact Union Pacific Systems Consultant at (402) 544-7425 or (402) 544-0574 as soon as possible to determine whether this work will require:
 - a) An addendum to an existing agreement.
 - b) Modifications to existing agreements, or
 - c) Negotiations of a new agreement.
- 1.1.3 If additional right-of-way is to be occupied by a FIBOCO with preexisting facilities on Union Pacific right-of-way, such fiber optic facilities including the precise limits of this additional right-of-way (within 1/10 mile) must be identified and documented within the appropriate agreement. Once the assigned Railroad engineer has approved the construction plans (Approved Plans), Railroad will prepare the appropriate agreement document(s) and submit to the FIBOCO for execution.
- 1.1.4 After the FIBOCO has executed these documents and the counterparts have been delivered to Railroad's Director - Fiber Optics and Asset Utilization and any required payments have been received by Railroad, arrangements will then be made with Railroad's assigned Construction Coordinator to commence work activities.
- 1.1.5 Plan approval, agreement execution and payment do **NOT** constitute approval to go to work.
- 1.1.6 You are approved to go to work when the following requirements have been met:
 - a) All permits/agreements are in place.
 - b) Plans are approved, and each work group has a stamped and dated copy.
 - c) The Agreement has been executed and payment has been received.
 - d) FIBOCO has obtained permission from the Systems Consultant of the Fiber Optics and Asset Utilization work group.
 - e) The Construction Coordinator(s) have been contacted, participated in a pre-construction meeting, established necessary flagging protection and concurred with a startup date for the work.
 - f) All field personnel are properly Railroad safety trained.

- g) FIBOCO has notified and secured a current Call Before You Dig (CBUD) Dig Ticket at 1-800-336-9193 from Railroad's Response Management Communications Center (RMCC) at 1-888-UPRR-COP (1-888-877-7267).

2 ENGINEERING PROCESS

This section is provided for the process of performing engineering by the Fiber Optic Engineering Group, on behalf of the Vice-President Engineering (hereafter referred to as VPE Representative) of the Union Pacific Railroad Company. Railroad reserves the right to change any of the standards in this documentation without prior notice.

2.1 PLAN SUBMITTALS

New or revised plans shall be submitted to the Fiber Optic Engineering Group for review and approval (See Section 3.8). Current contact information can be obtained through Union Pacific's web site:

<http://www.uprr.com/aboutup/telecom/contacts.shtml>, or by calling either 402-544-3719 or 402-544-3582.

- 2.1.1 Once the initial contract agreements have been implemented (see Section 1.1.2) for new fiber builds, contact the Fiber Optic Engineering Group to coordinate initial site reviews, Valuation Map (Val Maps) requests, procedures for preparation and submittal of plans for review and approval (See Sections 3.6, 3.7 and 3.8). Once the plans have been reviewed and approved, an approval letter will be sent to the appropriate FIBOCO contact detailing the next steps necessary that will need to be implemented – see Section 1.1.3
- 2.1.2 Modifications to existing Fiber Systems: For new laterals and relocations, etc, the plans will need to be submitted to the Fiber Optic Engineering Group for review and approval. Upon completion of the plan review, an approval letter will be sent to the FIBOCO, along with a copy of the Approved Plans. If the agreement needs to be modified, or if a new agreement needs to be made, the approval letter will indicate the process that needs to be followed – see Section 1.1.3.
- 2.1.3 All plans are date stamped with the same date as the approval letter. These plans are valid for one (1) year from date of issue. If the project has not been started by this time; the plans will need to be re-submitted for re-approval.

2.2 NOTIFICATIONS:

The Fiber Optic Engineering Group will notify the fiber carriers who have rights to be on our rights of way of new and impending projects. Not all projects will have notification letters sent. When a carrier (who may or may not have been notified) has a question regarding a potential project, please contact the appropriate VPE Representative, or your Union Pacific Fiber Optic Construction Coordinator (CC).

3 PROJECT SAFETY, PLAN, DESIGN AND CONSTRUCTION OF FIBER OPTIC CABLE SYSTEMS

These specifications are provided only as a guideline for the successful completion of fiber optic installations on Railroad right-of-way and are not to be taken as authority to construct without prior review and approval by the Railroad's office of the VPE Representative. Any items not covered specifically herein are to be in accordance with American Railway Engineering and Maintenance-of-Way Association ("AREMA") standards and recommended practices, subject to the approval of the VPE Representative. Railroad reserves the right to change any of the standards in this document without prior notice. Definitions used in this document follows in Section 7. Dimensions are given in English with metric units in parentheses.

3.1 GENERAL PROJECT SAFETY

- 3.1.1 Any person, contractor, or company who wishes to work on Railroad right-of-way is governed by On Track Safety (see Section 7). Where Railroad rules are more stringent, those rules will apply. Any work performed without obtaining proper authorization may permanently jeopardize your ability to be allowed on Railroad right-of-way.
- 3.1.2 **ALL ACCIDENTS ARE PREVENTABLE!!!** Workers are responsible for their safety and are accountable for their behavior on the Railroad's right-of-way. Take every precaution to prevent injury to yourself, other workers and the public. Report any dangerous condition or unsafe practice to the Construction Coordinator or appropriate Railroad representative. Be aware of, and work within, the limits of your physical capabilities.
- 3.1.3 Safety is always the top priority. Safety takes precedence over deadlines, production schedules, and all other considerations. Always take the safest course when uncertainty arises. Accidents are almost always the result of carelessness, unsafe practices, or lack of attention.
- 3.1.4 Work in a manner which will not disrupt Railroad operations, including, but not limited to, train movements, facilities, maintenance, and communications.
- 3.1.5 The FIBOCO is responsible to ensure that all safety precautions are followed by its own employees and those of its contractors and subcontractors, including appropriate translations as necessary to ensure complete understanding. This includes night security personnel. (Please refer to Section 3.5.4)

- 3.1.6 Keep the job site free from safety and health hazards. This includes, but is not limited to, installing proper barricades or warning devices, placing materials and equipment so that they do not create hazards and keeping roads clean of mud and debris.
- 3.1.7 Ensure that workers are competent and adequately trained in all safety and health aspects of the job. Only Railroad authorized personnel, as specified by agreement with the Railroad, are allowed on the right-of-way.
- 3.1.8 All FIBOCO personnel and its contractor(s) are required to attend safety training presented by a representative of the Union Pacific Fiber Optic Group, in addition to being governed by On Track Safety as required by the Federal Railroad Administration (FRA). Upon satisfactory completion of Railroad safety training, workers will be issued an annual "Safety Trained" sticker for their hard hats that must be displayed at all times while on Railroad's right-of-way.

SPECIAL NOTES:

- a) Safety stickers are non-transferable. If stickers are prohibited on hard hats due to regulatory requirements, they need to be displayed by other means.
 - b) Internet based Safety/Security courses such as "Contractor Orientation" and "e-RAILSAFE" complements, but are not substitutes for, the Union Pacific Fiber Optic Group's Safety training program.
- 3.1.9 Additional safety training will be required for any persons who will be working on bridges or other above ground installations. These procedures are outlined in Section 3.16.
- 3.1.10 Job briefings are required prior to beginning work each day. Additional job briefings are required when working conditions or procedures change, or other workers enter the working limits. After work begins, if person(s) arrive who missed the original job briefing, then another job briefing must be performed. Minimum information must include:
- a) An explanation of the work to be performed. Include the what, why, when, where and who. What safety precautions are necessary?
 - b) A designation of who is the Employee in Charge (EIC), and if working limits overlap, who will be the sole EIC.
 - c) A discussion of all potential hazards.
 - d) The issuance of assignments and appropriate explanations.
 - e) An understanding of the safest course.
 - f) The designated work zones.
 - g) A designated place of safety where workers clear for trains.
 - h) The issuance of instructions.
 - i) Completion and complete understanding of the Emergency Response Form (Exhibit R).

- j) Establishment of translation for non English speaking members of the work group.

3.1.11 Work is permitted for a maximum of ten hours each day between sunup and sundown. Good visibility is required at all times work is performed. No work is permitted on Sundays or Railroad holidays. Railroad holidays are as follows:

New Years Day – Presidents Day – Good Friday – Memorial Day (Monday) – Independence Day – Labor Day – Thanksgiving – Day after Thanksgiving – Christmas Eve – Christmas Day – New Years Eve.

Note: Commuter Operations may recognize other holidays and establish other work periods. You will be required to honor these holidays and work periods.

3.1.12 Firearms of any kind are strictly forbidden.

3.1.13 Using, possessing, or working under the influence of alcohol and/or drugs is not permitted. This includes prescription drugs that cause drowsiness.

3.1.14 Smoking is prohibited on all company property, including mechanical facilities, along the right-of-way, in office buildings and all service unit facilities. This includes company vehicles, equipment and in Railroad sponsored meetings held at off-site locations.

3.1.15 Cell Phones and Computers

When cell phone use is allowed, workers must follow all applicable federal, state and local laws. Use of cell phones (including their PDA functions) and computers is governed by the following:

- a) Before using a cell phone or computer, determine that it's safe to do so.
- b) FIBOCO representatives must not use cell phones when close to any track or when in close proximity to workers or equipment working on or off-track. If use of phone is necessary, move to outer edge of right-of-way.
- c) Cell phone use is allowed in the performance of prearranged job duties or in an emergency.

3.1.16 It is imperative that the FIBOCO document every accident and personal injury on Railroad right-of-way (please review Section 3.2.7), the FIBOCO must provide a final report for each incident to the Director - Fiber Optics and Asset Utilization. Photographs, when available and appropriate should be included.

3.1.17 It is the FIBOCO's responsibility that any product, waste, or other refuse is handled and/or disposed of in accordance with all applicable governmental regulations and Railroad policies. It is the FIBOCO's responsibility to prevent fuel or lubricants from

being released into the environment. In the event of a spill or release into the environment, notify the RMCC immediately.

- 3.1.18 The FIBOCO is responsible for any of its contractors and their subcontractors to be knowledgeable of the policies of Railroad, and will require all work to be in compliance with these standards. Only Railroad authorized personnel, as specified by agreement with the Railroad, are allowed on the right-of-way. All Railroad authorized personnel working within the right-of-way must be willing and able to supply proof of identity when and if requested by Railroad personnel.
- 3.1.19 It is the FIBOCO's responsibility to inform Railroad, in writing, of any name, ownership or address change.
- 3.1.20 Do not disclose information about Railroad to anyone that does not have a "need to know". If questionable, contact your authorized Railroad representative. Never take action that will put you in harm's way. Report all trespassers or suspicious people to the RMCC.
- 3.1.21 The Railroad has locations in which Remote Controlled Locomotives (RCL) operate. These areas are identified as RCL Zones. Within these zones, typically found in yard locations, positive train protection must be employed which will be coordinated by the CC.

3.2 EMERGENCY RESPONSE PLAN

- 3.2.1 Keep a list of local emergency phone numbers and addresses accessible to all employees at the job site. Include Railroad contacts on the list. See Appendix – Exhibit R.
- 3.2.2 Report by the first available means of communication any accidents; personal injuries; defects in tracks, bridges, signals, utilities or communication facilities; or any unusual condition that may affect the safe operation of the Railroad, or installed fiber optic systems.
- 3.2.3 If someone is injured, do everything possible to care for him or her. Maintain proper first aid kits on the job site at each crew location. Keep first aid kits in plain sight and accessible.
- 3.2.4 If a personal injury accident, loss of life or damage to property occurs, secure the names of all persons involved, including all persons at the scene when the accident occurred and those who arrived soon after.
- 3.2.5 Avoid derailment sites. If you do not have to be there, move to a safe distance. If FIBOCO employees or contractors do have to be in the area, obtain permission from the appropriate Railroad representative in charge before beginning work at the site.

Be careful when working around a derailment. Hazardous materials may be present. Some may even be lethal if inhaled or absorbed through the skin.

- 3.2.6 Immediately report to the Railroad's CC or Railroad RMCC at 1-888-UPRR COP (1-888-877-7267), any hazardous materials encountered or unearthed during construction or maintenance of the fiber system on the Railroad's right-of-way.
- 3.2.7 Report any damage to Railroad or outside property immediately to the CC when working on any Railroad property. All accidents or personal injuries must be reported immediately to the CC. The FIBOCO must document every accident and personal injury on any Railroad right-of-way, and provide a report of each incident to the CC.

3.3 PERSONAL PROTECTIVE EQUIPMENT

3.3.1 The following equipment is mandatory when working on the Railroad's right-of-way:

- a) A hard hat conforming to ANSI national standard Z89.1 Designer hard hats are unacceptable, (e.g. cowboy hats). Hard hats should display the contractor's company logo or name, unless otherwise authorized by the Railroad.
- b) Safety glasses conforming to ANSI national standard Z87.1 (FDA approved prescription glasses, or nonprescription safety glasses).
- c) Sturdy safety-toe footwear. All safety toe footwear must meet ANSI Z41.1, Standard Class #75. Tennis shoes and regular low cut casual shoes are not acceptable.
- d) Hearing protection when appropriate.
- e) Highly visible orange outer wear that include reflective striping conforming to American National Standards Institute (ANSI) Class II outer wear. However, welders or other hot work activities must wear required protective clothing as appropriate.

3.3.2 Proper attire is required when working on the Railroad's right-of-way that allows you to perform your duties efficiently and safely. When working outside, employees must wear trousers which cover the legs.

Clothing must not:

- a) Interfere with vision, hearing and free use of hands and/or feet.
- b) Block peripheral vision. When hooded sweatshirts and/or coats or similar type clothing are worn, they must be secured around the face to prevent the blocking of peripheral vision.
- c) Be torn, baggy, or ragged.
- d) Be so loose that it will snag easily or catch on Railroad cars, engines, tools, machinery or other equipment but must allow freedom of movement.

- e) Be worn so it creates the possibility of being caught or may affect one's safe performance of their duties i.e. neckties or similar clothing.

Shirts must:

- a) Have at least quarter-length sleeves and cover the back, shoulders, chest and abdomen.
- b) Provide protection from sun, insects, abrasions or scratches.
- c) Be buttoned. Anyone working around equipment or moving machinery in which a shirt might become entangled must have their shirt tails tucked into their trousers.

3.3.3 Observe safety practices that eliminate slips, trips and falls. Avoid objects, obstructions, holes and openings and be alert to underfoot conditions. Aisles, stairways and walkways must be kept free of tools, trucks, materials, equipment and obstructions.

Precautions to avoid slips, trips and falls:

- a) Perform your work to avoid creating hazards.
- b) Maintain good housekeeping.
- c) Clean up spills.
- d) Erect barricades, signs, or cones where appropriate.

Take precautions to avoid slipping on:

- a) Snow, ice, wet spots or other hazards caused by inclement weather. Use appropriate footwear and accessories and/or spread sand/salt mixture (as appropriate) on ice before proceeding when icy conditions exist.
- b) Slick surfaces such as recently washed, waxed floors, oil, grease or soap on the walkway.
- c) When walking, keep your eyes on the pathway and if hazardous under foot conditions exist:
- d) Keep your hands out of pockets for balance.
- e) Take short, deliberate steps with toes pointed outward.
- f) When stepping over objects, such as rails, be sure your front foot is flat before moving your rear foot.
- g) Do not run except when necessary to prevent injury to themselves or others.

3.4 TRAIN MOVEMENT AND WORKING NEAR TRACKS

3.4.1 Be alert to train movement. Expect the movement of trains, engines, Railroad cars, or other movable equipment at any time, on any track, and in either direction, even Railroad cars on sidings that appear to be stationary or in storage. Stay at least 100

feet (30.48 meters) away from the ends of stationary Railroad cars when crossing the track, and never climb on, under or between Railroad cars. Look both ways and walk single file while crossing tracks.

- 3.4.2 Never rely on others to protect you from train movement. Watch for yourself! **The responsibility is yours for safety on the Railroad.**
- 3.4.3 Do not stand on the track in front of an approaching engine, Railroad car or other equipment.
- 3.4.4 Be aware of the location of structures or obstructions where clearances are close.
- 3.4.5 NEVER stand or walk on Railroad tracks, either between the rails or on the ends of ties unless **ABSOLUTELY NECESSARY**. If your work requires being within the track structure, typically within 4 feet (1.22 meters) of the nearest rail, in addition to ensuring that proper protection is provided before fouling any track, you will also be governed by On Track Safety rules, no matter how small the job is. See Section 3.6- Railroad Flagging/Protection. Stay clear of tracks whenever possible. Trains can approach with little or no warning. You may not be able to hear them due to atmospheric conditions, terrain, noisy work equipment, or passing trains in multiple track territory.
- 3.4.6 No work is allowed within 50 feet (15.24 meters) of the centerline of the nearest track while trains are passing the work site. Always stand as far back as possible to prevent injury from flying debris or loose rigging. Also, observe the train as it passes and be prepared to take evasive action in the event of an emergency.
- 3.4.7 NEVER remain in a vehicle that is within 50 feet (15.24 meters) of a passing train, and do not drive near moving trains. Move vehicles away from the tracks at least 50 feet (15.24 meters), or park the vehicle away from the tracks and walk to a safe distance whenever trains pass.
- 3.4.8 Never stand on or between adjacent tracks in multiple track territory when a train is passing.
- 3.4.9 Never walk, stand or sit on the rails. The rail surface can be extremely slippery. Step over rails when crossing tracks.
- 3.4.10 Stay away from track switches. The switch points can move unexpectedly with enough force to crush ballast rock! Stay away from any other Railroad devices you are unsure of.

3.5 RAILROAD FLAGGING/PROTECTION

- 3.5.1 Certain projects will require the assistance of a qualified Railroad flagger. Three (3) weeks advance notification of the Railroad is required before entering the Railroad's

- right-of-way for non-emergency situations so that flagging protection can be **DETERMINED BY THE RAILROAD** and secured. For emergency situations, contact the Railroad immediately at 1-800-336-9193.
- 3.5.2 A Railroad flagger may be required for protection any time you are on the Railroad's right-of-way. A Railroad flagger is not authorized to regulate train frequency or train speeds, but is provided to ensure that the track is cleared for approaching trains.
 - 3.5.3 Every workday must begin with a job briefing. When utilizing a flagger, everyone must have a working knowledge of the flagging limits, time limits and location to which everyone will clear for any train movements. (Please refer to Section 3.1.10)
 - 3.5.4 Effective communication between the FIBOCO, the contractor, the CC and the Railroad flagger is imperative! The Railroad flagger will be responsible for clearing any movement of workers and equipment near the tracks, no matter how minor.
 - 3.5.5 Do not interfere with a Railroad flagger who is communicating by radio with the dispatcher or other Railroad employees. **Wait** until the Railroad flagger is finished and able to give you full attention. **DO NOT ASSUME A MOVE IS CLEARED BY SOMETHING OVERHEARD ON A RADIO CONVERSATION.**
 - 3.5.6 The Railroad flagger providing protection for train movement for a construction crew is restricted by time and location limits given by train dispatchers, and the flagger may not be able to assist crews outside of those limits.
 - 3.5.7 Take the time to prepare your schedule for each day in advance and discuss the operations with the CC so protection can be arranged. Protection may need to be secured by noon on the day before (or sooner) to avoid job delays. Fencing in lieu of flaggers may be used at the discretion of the CC.
 - 3.5.8 FIBOCO crew locations and the number of crews may be restricted depending on Railroad flagger availability, job site access and adequate radio communications.
 - 3.5.9 Do not begin work late in the day if it cannot be completed or secured to the satisfaction of the CC.
 - 3.5.10 Flaggers are required any time there is a bore underneath active Railroad tracks.

3.6 PLANNING

- 3.6.1 Obtain and execute a "Fiber Optic Survey Agreement" or "Right of Entry Agreement" prior to entering the Railroad's right-of-way. (See Section 1.)
- 3.6.2 Coordinate the engineering criteria, from the preliminary route inspection through the actual route design, with a VPE Representative. (See Section 2.)

- 3.6.3 The Railroad will furnish one reproducible set of available Railroad right-of-way maps (Valuation or Track Maps), bridge plans and other necessary plans of the proposed route as specified in the "Fiber Optic Survey Agreement". If available, electronic copies of the map or plan may be substituted. The Railroad does not guarantee or warrant information on right-of-way maps. **It is the responsibility of the FIBOCO to verify property ownership.**
- 3.6.4 A VPE Representative will participate and accompany the FIBOCO representatives during a preliminary route inspection to address any special design considerations and constraints.
- a) Several weeks advance notice may be necessary to arrange and schedule a route inspection requiring the use of a hy-rail vehicle.
 - b) During the route inspection, mark in red on copies of the Railroad maps or condensed profiles, the proposed fiber system route agreed to by both companies. Use this document in the preparation of construction drawings.
- 3.6.5 When planning a fiber system project:
- a) Identify and note on maps any wetlands, and potential impact of the project on such areas.
 - b) Note vegetation, property uses and topography not indicated on maps.
 - c) Note cuts and fills.
 - d) Note soil conditions.
 - e) Identify potential track crossings, particularly under-track bores.
 - f) Note locations of Railroad structures and potential obstructions.
 - g) Document surrounding area by use of digital photography as conditions permit.
- 3.6.6 You are governed by all of the Railroad's instructions and regulations, in addition to On Track Safety, while conducting preliminary investigations and route surveys on the Railroad's right-of-way, per Sections 3.1, 3.2 and 3.3.
- 3.6.7 Special permission from the Director - Fiber Optics and Asset Utilization is required for the use of multi-purpose utility vehicles (MUV's) on the Railroad's right-of-way.
- a) MUV's are to be operated as a work vehicle, adhering to all safety instructions and operating practices recommended by the manufacturer.
 - b) Speed of MUV vehicles should never exceed walking speed and cross tracks only at approved crossings, and never operated closer than 25' (7.62 meters) to the track.
 - c) A MUV is never to be left running when unoccupied by the driver.
 - d) Each occupant must be properly seated and seat belted.
 - e) Must not be used in conjunction with other vehicles or used to tow.
 - f) Avoid uneven terrain, keeping on access roads unless otherwise approved.

- 3.6.8 The Railroad requires at least two-persons per survey crew.
- 3.6.9 The use of measuring wheels will be allowed only over the top of proposed running lines. Use of the wheel within 10 feet (3.05 meters) of the nearest rail is prohibited. Never deface Railroad property. This includes marking property to establish stationing, during survey, design and construction.
- 3.6.10 Call the CBUD desk at 1-800-336-9193 prior to entering the Railroad's right-of-way. If you plan to place anything that penetrates the ground more than 18 inches (48 centimeters), you must call the CBUD desk, and a locate may be required. This includes marking stakes or signs.
- 3.6.11 Obtain permission to occupy the property or right-of-way of landowners other than the Railroad. It is the FIBOCO's responsibility to obtain any permits, if required.
- 3.6.12 You are expected to conduct yourself in a controlled and respectful manner on the Railroad's right-of-way.

3.7 DESIGN (General Requirements)

- 3.7.1 Detail all fiber facilities including lines, repeater sites, junctions, and structures. Call the Union Pacific's Railroad Call Before You Dig (CBUD) desk **1-800-336-9193** to obtain a dig ticket for fiber locates or field meets with existing fiber optic carriers.
- 3.7.2 Locate and identify buried utilities and other potential obstructions. (Please refer to current edition of Common Ground Alliance Best Practices)
- 3.7.3 The fiber system is to be installed near the outer limits of the Railroad's right-of-way. Keep the Fiber Systems running line as straight as possible while maintaining a consistent distance from centerline of nearest track. Design and detail all installations on, over, or under Railroad property of durable materials designed for long service life and relatively free from routine servicing and maintenance. Conformance with current applicable material specifications and codes is mandatory. These include but are not limited to lines, repeater sites, junctions and structures.
- 3.7.4 Design the fiber system to be installed on the field side of all Railroad structures, including bridges, signal facilities, buildings and platforms.
- 3.7.5 If the fiber system has to be placed under an existing signal or communication structure, place the system a minimum of 10 feet (3.05 meters) under natural ground. This extra depth may also be required in "signal sensitive areas" such as interlocking or control plants.

- 3.7.6 If the fiber system has to be located under (vertically) existing signal or communication wires, a minimum 2 feet (.61 meters) of separation is required.
- 3.7.7 Fiber optic cable must not be installed within 5 feet (1.52 meters) horizontally of underground power or signal power lines, unless suitably insulated.
- 3.7.8 If the fiber system is designed within 30 feet (9.14 meters) of a centerline of nearest track or structure of any type, excavations within this area may require shoring designed to include train or structure surcharges. In such cases, submit shoring plans with calculations, stamped by a licensed civil engineer, to the VPE Representative for approval prior to construction. The submittal can be made by the contractor after the project has been awarded; however, the project may be delayed waiting for approvals. See Section 3.8 - Trenches and Excavations and Exhibit I.
- 3.7.9 Do not design fiber system components that create stumbling hazards on the Railroad's right-of-way. Placement of marker signs in Railroad access roads is not allowed. Marker signs should be installed at the outer limits of the Railroad right-of-way.
- 3.7.10 Design the fiber system to be installed a minimum of 42 inches (1.07 meters) below natural ground, except as noted herein. Warning tape should be placed above the buried facility. Refer to Exhibit D & N.
- 3.7.11 In the event local ground conditions prohibit the placement of the fiber system at a depth of at least 42 inches (1.07 meters), the fiber system must be encased, and specific approval by the VPE Representative is required. If rock is encountered and prevents a depth of 42 inches (1.07 meters), the fiber system must be cut into the rock at a depth of 18 inches or greater, provided proper grouting and cable protection is used. Cutting the rock less than 18 inches (46 centimeters) requires special permission of the VPE Representative. Refer to Exhibit M.
- 3.7.12 Design the fiber system to be buried a minimum of 60 inches (1.52 meters) below the bottom of **all** culverts on the Railroad's right-of-way, or around the end of the culvert (field side) and 60 inches (1.52 meters) below the bottom of the cleaned out ditch. Only after specific evaluation by the VPE Representative will any system be allowed to be placed over the top of any culvert. Refer to Exhibit D.
- 3.7.13 Avoid the slope of cut or fill sections when designing the running line. Design the fiber system to run over the top of a cut section whenever possible. Refer to Exhibit K.
- 3.7.14 If the fiber system has to be located in the ditch, place the system a minimum of 60 inches (1.52 meters) beyond the toe of the slope and a minimum of 60 inches (1.52 meters) below the bottom of the existing flow line. The FIBOCO should consider placing the fiber system at extra depth and/or in protective casing for protection when

Railroad personnel clean the ditch. Also, place the warning tape so it is not disturbed during normal ditch cleaning by the Railroad.

3.7.15 Do not design the fiber system to attach to the Railroad's bridges to cross waterways, highways, etc., unless no other feasible alternative exists and subject to the following:

- a) Fully explore all other options before submitting requests to attach the fiber system to the bridge.
 - 1) In no instance will the Railroad approve permanent attachment of the fiber system to a timber bridge, nor to the handrails of bridges.
 - 2) No bridge abutments or piers shall be allowed to be core bored. All attachments are to be placed around the abutments and/or piers.
- b) Submit separate bridge attachment designs to the VPE Representative for approval prior to construction. Include the following with your request:
 - 1) A full justification as to why it is necessary to make the attachment. Expedience or cost avoidance are generally not acceptable reasons.
 - 2) Detail drawings indicating type and placement of supporting brackets, the size and type of fasteners and conduit.
 - 3) Photos of the bridge, track, and the fill approaches to the bridge.
 - 4) Details at and around bridge backwalls.
 - 5) A detailed work plan of the attachment process, including all proposed work equipment (such as rail mounted work equipment, cranes, and boom trucks) and all other mechanized equipment to be approved by VPE Representative prior to construction.
 - 6) Design bridge attachments that will not delay future repair, replacement, and other construction to take place on or near the bridge (superstructure and substructure).
 - 7) Include in the design extra cable in a protected facility near the bridge so the bridge can be raised if necessary and without delay to Railroad or FIBOCO operations.
 - 8) Design the fiber system so it does not obstruct the bridge bearings. Refer to Exhibit C.
 - 9) Design the fiber system to be installed on the downstream side of the bridge.

- 3.7.16 Design handholes, splice boxes, and manholes for appropriate loading conditions. In general, locations within 15 feet (4.57 meters) of centerline of nearest track should be designed for a Cooper E80 surcharge, while all other installations should withstand AASHTO H-20 highway loading requirements, in addition to soil pressures. Installation of handholes or manholes in yards and near heavy vehicular traffic areas may require concrete fill around the boxes. Include plans with typical handhole and manhole details with the project plan submittal. More stringent design criteria may be required.
- 3.7.17 Design handholes and manholes that utilize a minimum right-of-way corridor within the running line. Handholes that allow cable slack should be placed at locations that allow Railroad maintenance to minimize right-of-way disturbance. Handholes and manholes used for splicing multiple duct systems need to be placed at the maximum distance from each other without clustering. See Exhibit O.
- 3.7.18 The design of handholes, manholes and spliceholes should not be within 100' (30.48 meters) of existing Railroad signal or communication buildings, facilities or existing regen compounds unless required for tying to the existing facility. See Exhibit O.
- 3.7.19 Installation of fiber systems on pole lines within the Railroad right-of-way are approved on an individual basis.
- 3.7.20 Any overhead crossing of the track by the fiber system must adhere to the Real Estate rules for Wireline Installation Procedures for Crossings per the link:
<http://www.uprr.com/reus/wireline/procedur.shtml>
- 3.7.21 Designs must comply with all Federal, State and/or Local Laws. A Storm Water Pollution Prevention Plan is required for disturbances greater than one acre.

3.8 DRAWINGS

RAILROAD METHODOLOGY FOR EQUATING FIBER OPTIC CABLE LOCATIONS TO RAILROAD TRACK AND RIGHT-OF-WAY MAPS. Refer to Exhibit B:

- 3.8.1 Drawing Submittal Minimum Requirements:
- a) Title page indicating FIBOCO name, Railroad subdivision name and Mile Post, city (or city pair) and state(s).
 - b) Location map (can be included on title page).
 - c) Drawing format: 11"x17", professionally prepared with computer-aided drafting (CAD).
 - d) Include copies of the original As Built on all additions, moves and changes.
 - e) Standard detail sheets for handholes/manholes, construction methods, marker posts, and other typical features.

- f)** Design drawings for all encroachments on Railroad right-of-way. (Details for work off Railroad right-of-way may be included for illustration or clarity, but will not be included in the approved plan set.)
- g)** Include on the drawing set the FIBOCO project number for reference.

3.8.2 Submit construction plans at a scale of 1"=100' (2.54cm=30.48 meters) in suburban and heavily populated areas or where complex detail is required. A 1"=400' (2.54cm=121.92 meters) scale may be used in rural areas. Exceptions must be approved by the VPE Representative.

3.8.3 Show the following on the design drawings:

- a)** All necessary dimensions measured at right angles to the centerline of the nearest mainline track.
- b)** The Railroad's right-of-way limits, mainline track, sidings, spur tracks, Railroad mile markers, and Railroad station names, on both sides of the track, not just the side of the proposed fiber optic running line. Include Railroad stationing and, if used, corresponding FIBOCO stationing for each landmark. Station names are found on Railroad Val Maps drawings for the route.
- c)** Overpasses with road name and the Railroad's mile marker designations. Show bridge piers in relation to the Railroad's track, the fiber system and any culverts.
- d)** All utility crossings (both underground and overhead), parallel underground utilities, pole lines, signals, signal houses, and other signal facilities.
- e)** Public and private street and road crossings with street names. Show Railroad stationing and corresponding FIBOCO stationing at road centerline.
- f)** Rivers, fences, landmarks, and any other facilities, which will aid in identifying the fiber system location.
- g)** The Railroad "Call Before You Dig" number, 1-800-336-9193, and instructions for its use.
- h)** Fiber system running line changes and bore locations indicating Railroad stationing and, if used, corresponding FIBOCO stationing.
- i)** Conduit size and count, and fiber cable count.
- j)** North arrows, scales and directional orientations on all sheets. Directional orientations include Railroad station names and/or mile post numbers in each direction at the edge of each sheet.
- k)** County names.
- l)** Railroad bridges and culverts with proper bridge/culvert number. (The bridge/culvert number is usually, but not always, related to the mile post location and can be found on the Railroad Val Map for the route, as well as on the structure.)
- m)** See section Trenchless Fiber Systems, Section 3.13 for plan submittal requirements.
- n)** Handholes: See Section 3.7.16, 3.7.17 and 3.7.18 for handhole plan submittal information.

- 3.8.4 Include "original" and "revised" dates on all revised drawings.
- 3.8.5 Show the location of fiber system marker signs on the design drawings, and submit a detail of the sign, including color of the sign, for Railroad approval. This also applies to aerial marker signs.
- 3.8.6 Furnish drawings of each regen site along with the running line drawing. This drawing should show the same information mentioned in the previous sections. Other details to be included are: the distance from the regen building to the centerline of all tracks, grade crossings, and other facilities; power supply required for the regen building including voltage, above ground clearances, below ground dimensions and building access.
- 3.8.7 Include all boring and casing details on the design drawings. This includes, but is not limited to, dimensions, bore pit locations, and casing specifications. Include a bore profile for all under-track bores.
- 3.8.8 Show on the design drawing(s) the reasons for deviations in the running line of the fiber optic cable system, such as steep banks, water crossings, ditches, obstacles, etc.
- 3.8.9 Railroad design requirements may be modified to permit installation at unique locations, but only after the FIBOCO has exhausted all alternatives, and the office of the VPE Representative has reviewed and accepted the plans. Submit, along with requests for deviations from these standards, detailed drawings depicting the deviations and the reasons for them.
- 3.8.10 All of the dimensions in this manual have been given in English units with the metric unit equivalents in parentheses. However, all drawings submitted for Railroad approval need to have dimensions given in English units only.

3.9 CONSTRUCTION

- 3.9.1 Proper documentation is required for working on Railroad right-of-way. Each contractor/employee must maintain and provide, upon request, proper identification while on Railroad right-of-way. The following items must be maintained and provided to the CC prior to the pre-construction meeting and kept onsite for the duration of the project:
 - a) Approved Plans by the Railroad VPE Representative.
 - b) Railroad approval letter.
 - c) Damage Prevention procedures including location methods of other utilities.
 - d) Storm Water Pollution Prevention Plan (for disturbances greater than 1 acre) and other documents and permits as required by Federal, State and/or Local laws.
 - e) Railroad approved shoring plans (when shoring is required).
 - f) Railroad Emergency Response Form (Exhibit R).

- 3.9.2 Any excavation, no matter how large or small, requires an advance telephone call a minimum of 48 hours in advance except in an emergency, to the Railroad CBUD desk at 1-800-336-9193. Make sure the applicable One-Call Center has been notified pursuant to each State requirement. (Please refer to current edition of Common Ground Alliance Best Practices)
- 3.9.3 The CC is the primary point of contact during the duration of the construction project.
- a) Complete arrangements with the CC for safety training and protection of construction operations prior to any construction activity on the Railroad's right-of-way.
 - b) The starting date of construction may be affected by the availability of Railroad CC's and/or flaggers.
 - c) Contact and coordinate your activities with the CC at least 3 weeks prior to scheduling a project start date with a contractor.
 - d) The CC must be apprised of all project details during the duration of construction activities, whether or not he or she is present on site every day, and whether or not other UP employees become involved in the scope of the project (such as a flagger, a track manager, a construction manager, or others).
- 3.9.4 Affix the annual "Safety Trained" stickers to hard hats and have them visible when working on the Railroad's right-of-way. See Section 3.1.8 - Safety.
- 3.9.5 Follow the approved construction drawings.
- a) Use only construction drawings which have the Railroad approval stamp on the cover sheet and initialed date stamps on all other sheets. The use of drawings not approved by the VPE Representative is strictly prohibited.
 - b) The conduit system is to be constructed at the designed location. Obtain approval from the CC for any deviation to the construction drawings and indicate such changes on the construction drawings.
- 3.9.6 Install the fiber system a minimum of 42 inches (1.07 meters) below ground, except as noted herein.
- 3.9.7 Mechanized construction within 5 feet (1.52 meters) of existing facilities requires coordination of mechanized construction methods with each affected facility owner at unique locations.

- 3.9.8 Install the fiber system a minimum of 60 inches (1.52 meters) below the bottom of all culverts on the Railroad's right-of-way, or around the end of the culvert (field side) and 60 inches (1.52 meters) below the bottom of the cleaned out ditch. Refer to Exhibit D.
- 3.9.9 Do not install the fiber system in the slope of cut or fill sections, and do not bench any cut or fill sections. See Appendix – Exhibit G. Locate the fiber system over the top and on the field side of the back-slope of a cut section whenever possible.
- 3.9.10 In the event the fiber system has to be located in the ditch, place the system a minimum of five feet beyond the toe of the slope and a minimum of 60 inches (1.52 meters) from the bottom of the existing flow line. The FIBOCO may want to consider placing the fiber system at extra depth and/or in protective casing for protection when Railroad personnel clean the ditch. Also, place the warning tape so that it is not disturbed during normal ditch cleaning by the Railroad.
- 3.9.11 Stabilize any waterways that have been plowed or cut. Use rip-rap or other approved erosion control methods.
- 3.9.12 Encase in galvanized steel pipe or black iron pipe [Specified Minimum Yield Strength of 35,000 psi (241,318 kPa) or above] all fiber system lines under tracks. Use of plastic pipe that conforms to the same specifications to eliminate the Hot Work process is suggested. For depths greater than ten feet (3.05 meters) below natural ground, see Section 3.3.2 - Trenchless Installation of Fiber Systems. Place casings a minimum of 60 inches (1.52 meters) below the base of rail or natural ground, whichever is greater. Use Railroad approved installation methods. Wet bores under tracks are not allowed.
- 3.9.13 Extend the casing a minimum of 30 feet (9.14 meters) from the centerline of nearest track, measured perpendicular to the track, or longer, to stay out of cuts and/or fills. See Section 3.7 Design.
- 3.9.14 All boring operations are subject to the following conditions:
- a) The machine operator follows all current OSHA regulations, including the use of grounding mats and other safety measures.
 - b) The machine operator has control over the direction of the boring tool.
 - c) Red Zones of 10 feet (3.05 meters) must be established around all existing facilities not positively located. Voice communication must be maintained between machine operator, locator, and anyone else occupying the Red Zone of the drilling operation.
 - d) All tools and equipment must be present at the job site prior to the start of the drilling operation.
 - e) The bore crew must have, in their possession, a copy of the permit authorizing the company to perform work on Railroad right-of-way, and a copy of the

approved drawing and specifications for the bore work location. Bore profiles must be approved by the CC, prior to the start of all bores.

- f)** Casing pipe is required on all under track bores involving multiple duct systems. Back reaming must be completed prior to pulling back uncased multiple duct systems on parallel to track bores.
- g)** When possible, mark the proposed running line every 5 feet (1.52 meters) to 10 feet (3.05 meters), using a longitudinal line, prior to the bore operation. Mark the actual bore-head location with a paint spot at the end of each stem push. Only white paint is approved for this use.
- h)** The bore is not allowed to deviate more than 6 inches (15 centimeters) from the proposed marked running line, and the ends of the bore must be at the designated depth.
- i)** The drilling and/or reaming operation must utilize a locating system, such as a Sonde (radio transmitter/beacon), in all forward and reverse movements.
- j)** The entry angle must not exceed a 1 to 10 slope, and must comply with equipment manufacture specifications.
- k)** Slurry use is kept at a minimum and only used for head lubrication and/or spoils return. Calculate anticipated slurry use and monitor slurry use during the bore operation to determine slurry loss into the surrounding soil. Bentonite slurry is required and pressures must be controlled for the type of soil being bored. All voids created during the bore operation must be grouted. Using slurry other than bentonite requires CC approval, and must not leave voids or contaminant the soil.
- l)** Slurry must be contained during the bore operation and must be removed prior to backfilling with dry dirt.
- m)** Pull back methods use mandrels up to one and one-half times the diameter of the casing, up to a casing diameter of 12 inches (304.8 millimeters).
- n)** Non-standard bores, misdirected bores, or other unsuccessful bores that have been approved to be abandoned by the CC are to be filled with non-shrinking grout (or equivalent) including all voids. Documentation of the failed bore must be provided to the CC.
- o)** If a bore is unsuccessful, future attempts are made only with the approval of the CC. Additional attempts, with CC approval, will be re-drilled through the abandoned bore, including abandoned conduits, prior to obtaining CC authorization to relocate the bore.
- p)** The bore operation will be stopped if any damage occurs to the Railroad subgrade or track structure and it shall remain inactive until corrective measures are taken at the direction of the CC. The FIBOCO is liable for any damage done to the Railroad's right-of-way, structures, or train operations.
- q)** Auger heads are not allowed more than 6 inches (152.4 millimeters) ahead of the casing being inserted.
- r)** Any parallel-to-track bore that is made in either a cut bank or fill section will be located a minimum of 60 inches (1.52 meters) below the toe of the ballast section, or natural ground, or 84 inches (2.13 meters) below the base of rail, whichever is lower. Refer to Exhibit J.

- s) Any void greater than 2 inches (50.8 millimeters) between the conduit and the casing will require cobblestone, a fabric filter, or the ends to be closed off at the discretion of the CC.
- t) Any Directional under-track bores are installed a minimum depth of 12 feet (3.66 meters) below the base of rail, or 60 inches (1.52 meters) below the natural ground line, whichever is greater. Refer to Exhibit N.
- u) Maximum size of the finished product is 12 inches (304.8 millimeters).
- v) Bentonite slurry should be used to seal the hole with a minimum of 95% return.
- w) Bore stems and cutting heads may have to be left in the ground if they cannot be retrieved through the bore hole. Open excavation to retrieve the parts may not be possible.
- x) If an under track bore is at a depth of 12 feet (3.66 meters) below base of rail or more, a single duct system can be pulled back without a casing pipe. The pull back hole must be as small as possible and is not to exceed one and one-half times the diameter of the finished duct.
- y) When boring near creeks and streams, silt fences will be properly installed to prevent disturbed soil from flowing into the waterways, and remain in place after the bore has been completed.
- z) Crews must have access to shoring in the event of a utility cut.
- aa) The bore shall allow the path to be at a zero slope for a minimum of 30 feet (9.14 meters) from the centerline of the track, 2 feet (.61 meters) from the toe of the slope and 3 feet (.91 meters) beyond the ditch, whichever is greater.

3.9.15 When using a dry bore method, locate the fiber system a minimum of 60 inches (1.52 meters) below the base of rail or natural ground, whichever is greatest. Encase in galvanized steel pipe or black iron pipe [Specified Minimum Yield Strength of 35,000 psi (241,318 kPa) or above] all fiber system lines under tracks in a single casing. Use of plastic pipe that conforms to the same specifications to eliminate the Hot Work process is suggested. Extend the casing a minimum of 30 feet (9.14 meters) from centerline of nearest track, measured perpendicular to the track, or longer, to stay out of cuts and/or fills.

3.9.16 Locate any bore pits no closer than 30 feet (9.14 meters) from the centerline of the nearest track. Bore pits are not allowed in cut or fill sections of the roadbed. See Exhibit E.

- 3.9.17 Keep bore pits and other excavations to the minimum size necessary.
- 3.9.18 Use the most restrictive of either OSHA and/or Railroad approved shoring procedures on all trenches and excavations. (See Section 3.12 – Trenches and Excavations.)
- 3.9.19 Avoid the need for workers to be in trenches whenever possible. For example, when trenching in a conduit system, the pipe to be placed should be assembled above the trench and lowered down into the trench. When workers are required to go into an excavation, shoring requirements will govern. (See Section 3.9.18 above.)

Backfill, cover or fence all excavations when unattended. The CC will approve the protection method and the type of fencing material. Set fencing back at least 3 feet (91 centimeters) from the edges of the excavation. Set fence posts securely in the ground and insure the fencing is securely tied to posts with zip ties or some other tie wrap product.

- 3.9.20 No equipment is allowed on any track ballast section.
- 3.9.21 Do not foul the track ballast with dirt or other foreign materials.
- 3.9.22 Do not store or place equipment, supplies, materials, tools, or other items within 25 feet (7.62 meters) of the centerline of nearest track, or within 500 feet (152.4 meters) of road crossing.
- 3.9.23 Start clean-up and restoration of the Railroad's right-of-way immediately after the fiber system installation in each construction area and continue on a daily basis as the project progresses until complete. Ensure that any stumbling hazards are removed immediately. Railroad property disturbed by the installation, maintenance, removal and relocation of fiber facilities is to be kept at a minimum.
- 3.9.24 Remove any brush or items that cannot be chipped to 1 inch (2.54 centimeters). At the discretion of the CC, the contractor may have the option of chipping trees and brush generated in construction to 1 inch (2.54 centimeters) in size and blowing onto the right-of-way (away from the ballast section!). Take care not to foul the ballast, block ditches or culverts, or otherwise impede drainage.
- 3.9.25 Compact all backfill in excavations and trenches to 95% maximum dry density as defined in ASTM Standard D698. Use clean, suitable backfill material.
- 3.9.26 Install only VPE Representative approved bridge attachments incorporating the following:
 - a) Install extra cable in a protective facility near the bridge so the bridge can be raised if necessary and without delay to Railroad operations.
 - b) Install the fiber system so as not to obstruct the bridge bearings. Refer to Exhibit C.

- c) Exercise care in trenching between the toe of the roadbed slope and bridge backwalls, typically by hand-digging or dry boring.
 - d) Torch cutting or welding of bridge members is not allowed. Drill holes required for bracket attachment.
 - e) If brackets must be removed from a bridge, do not torch cut bolts. After removing the bracket, insert a bolt in the open hole and paint with galvanized paint. If the bridge is concrete, cut the bolt flush with the concrete surface.
 - f) Touch-up any scratched galvanized bridge surfaces, including bracket attachments, with galvanized paint.
- 3.9.27 Fall protection conforming to all Federal Railroad Administration and OSHA regulations is required for work performed on all bridges and above ground installations. See Section 3.15 – Bridges and Above Ground Installations.
- 3.9.28 Install handholes, splice boxes, and manholes per the requirements of Sections 3.7.16, 3.7.17 and 3.7.18. Install them so as not to create a stumbling hazard or to interfere with Railroad operations. Installation of handholes or manholes in yards and near heavy vehicular traffic areas may require concrete fill around the boxes. See Exhibit O.
- 3.9.29 Railroad signal personnel will locate, remove, and replace all guy wires on Railroad pole lines, if required.
- 3.9.30 Coordinate work on Railroad poles with the CC.
- 3.9.31 Follow applicable state and national electric codes for all pole work.
- 3.9.32 Obtain approval for all wire drops and splice locations from the CC prior to construction.
- 3.9.33 Obtain daily permission from the CC to climb the Railroad's poles to hang the fiber system. Ensure all power lines on the poles have been de-energized. Check the poles for structural integrity before climbing. Use climbing equipment conforming to OSHA regulations. In addition, comply with federal, state, and local laws and regulations.
- 3.9.34 Do not throw trash into any excavations.
- 3.9.35 Contain all construction-generated waste material and remove it to an approved disposal site. This includes, but is not limited to, excavated foundations, old dump sites, debris, concrete or masonry obstructions, organic matter, rocks, and boulders.
- 3.9.36 Remove all abandoned Fiber System facilities from the Railroad's right-of-way. Coordinate the method of cable removal with the assigned CC. Be advised: if the Railroad allows any abandoned cable to remain in place, the FIBOCO is not released from liability for damages to the Railroad or other parties using the right-of-way, or

the necessity of removal in the future. If the Railroad determines the cable to be a nuisance or impairment at a future date, the FIBOCO will be required to remove the cable at the FIBOCO's expense.

- 3.9.37 Any abandoned core bored backwalls will require repairs to fill the bore with a suitable grout. If brackets must be removed from a bridge, do not torch cut bolts. After removing the bracket, insert a bolt in the open hole and paint with galvanized paint. If the bridge is concrete, cut the bolt flush with the concrete surface. Touch-up any scratched galvanized bridge surfaces, including bracket attachments, with galvanized paint.
- 3.9.38 Regrade and clean construction sites to as good as, or better than, the condition they were before the project began. This may include replacing any vegetation by sodding, seeding disturbed areas with indigenous grass species, fertilizing and mulching. Perform clean-up and restoration as the project progresses. Do not wait until the end of the entire installation.
- 3.9.39 Immediately repair or replace any disturbed signs, poles, fencing and soil conditions to equal or better condition. Repair and/or monitor fences used to contain livestock. Ensure that livestock are not released onto the Railroad's right-of-way. Protect against erosion in disturbed areas that are subject to erosion. Use temporary erosion control as dictated by local conditions, such as rock, riprap, wash checks, hay or straw cover, or other material that is approved by the VPE Representative and does not interfere with Railroad operations, by applicable environmental regulations.
- 3.9.40 Do not operate heavy equipment on Railroad's paved roads located on the Railroad's right-of-way without prior approval of the VPE Representative. Use a protective covering over paved roads when crossing them with heavy equipment. Coordinate such moves with the CC.
- 3.9.41 When installing Fiber Systems on top of cuts, do not operate equipment or install cable within 5 feet (1.52 meters) of the top of the slope. This protects a 5 foot (1.52 meters) buffer zone where rubber tired and tracked equipment is not allowed to drive on the top soil. (Refer to Exhibit K)
- 3.9.42 Comply with all applicable federal, state, and local environmental laws and regulations. (Please refer to current edition of Common Ground Alliance Best Practices)
- 3.9.43 Where Public Utilities Commission requirements meet or exceed the requirements of the Railroad, those requirements will apply. This would include but not be limited to, safety, clearances and walkways. (Refer to Exhibit L)
- 3.9.44 When an undesignated or otherwise unknown underground facility is discovered within a work area, report such discovery to the CC. If the discovery is made during the locating phase of the work, contact the CC to determine if the original design will

be impacted. If damaged during excavation, cease operation, safely secure the area, contact the CC and the Railroad RMCC at 1-888-877-7267 and be governed by the authorized Railroad representative. Document the location on the As Built.

- 3.9.45 Locating and marking is required before excavation can begin. All utilities, active and inactive, are to be located and marked. The American Public Works Association (APWA) uniform color code follows:

White	Proposed Excavation
Yellow	Gas, Oil, Steam, Petroleum or Gaseous Materials
Red	Electric Power Lines, Cables, Conduit and Lighting Cables
Orange	Communication, Alarm or Signal Lines, Cables or Conduit
Green	Sewer and Drain Lines
Blue	Potable Water
Pink	Temporary Survey Markings
Purple	Reclaimed Water, Irrigation and Slurry Lines

(Please refer to current edition of Common Ground Alliance Best Practices)

- 3.9.46 Marker posts should be placed near the outer edge of the Railroad rights-of-way. This is not always possible since, for example, in areas where the right-of-way is extremely wide, adjacent land owners, farmers or others may be utilizing a portion of the Railroad right-of-way. As an example, if the right-of-way edge is 200 feet (60.96 meters) from the centerline of the track, and the farmer's fence is 150 feet (45.72 meters) from the centerline of the track, placement of the marker post at the right-of-way edge would result in a marker post in the middle of a field or pasture. In this case, a suggestion would be to place the marker post near the farmer's fence, or the established physical boundary.

- a) Marker posts should not be placed directly under utility poles. This practice results in an impaling danger to those climbing the poles for utility maintenance.
- b) Marker posts are intended to visually alert potential excavators to the presence of buried fiber optic facilities and as a means to instruct potential excavator(s) to "call before they dig". Do not cluster marker posts. It is suggested to place only one marker post, representing the FIBOCO, at intervals that do not hinder Railroad operation within the right-of-way.

- 3.9.47 Examples leading to marker post placement misunderstandings along rights-of-way are provided below to help identify and provide workable solutions to this portion of the construction project.

- a) General statements that suggest placement of markers posts to be within one foot (or other specified distances) off of the fiber optic running line is not a good recommendation.
- b) Marker posts placed consistently at one foot off of the fiber optic cable running line will set precedence, which others will make note of. Others will

assume that this is always the case. This is not always the case since circumstances will not always allow this. Also, when a post is knocked over, people tend to reset the post, which may or may not end up in the original location.

- c) If marker posts are placed within close proximity to the fiber optic cable running line and are struck by a vehicle, they could be driven through the innerduct and possibly the fiber cable.
- d) Fiber optic cable running lines are occasionally in a maintenance road. (Marker posts cannot be placed in the maintenance road, since they would effectively get knocked down and interfere with other operations.)
- e) Fiber optic cable running lines are occasionally in a ditch or waterway. (Marker posts cannot be placed in ditch or waterway, since they would interfere with maintenance and/or wash away.)
- f) Fiber optic cable running lines may have several running line changes in a given segment of the right-of-way. However, marker posts should not be placed in this manner. Marker posts should be kept as straight as possible, in consideration of maintenance operations of both the Railroad and of the FIBOCO.

- 3.9.48 Above all else, please exercise common sense and the safest course of action in the determination of marker post placement.
- 3.9.49 Collectively there have been many conversations regarding the correct placement of marker posts, and/or moving of misplaced posts. If previously placed posts interfere with drainage, right-of-way maintenance and/or maintenance roads, or create a safety hazard (such as an impaling hazard), such posts shall be moved.
- 3.9.50 When more than one FIBOCO shares the same general location, the placement of marker signs should utilize the same post whenever practicable.
- 3.9.51 In all circumstances, the use of common sense must prevail. **If common sense does not provide adequate direction, please contact Union Pacific's Director - Fiber Optics and Asset Utilization at (402) 544-0574 to further discuss.**
- 3.9.52 Ensure that proofing of the duct system allows fiber installation with minimal excavation. Additional excavation requires prior approval from the CC.
- 3.9.53 When proofing, the exit end of the duct system is considered a Red Zone and safety precautions must be taken to protect this area.
- 3.9.54 All construction must follow the requirements of Railroad and all appropriate state and national electric codes. Where conflicts exist between these guidelines and those of the state and/or national codes and rules, the stricter interpretation shall take precedence.

3.10 GENERAL FIRE PREVENTION SAFETY and HOT WORK PROCESSES

- 3.10.1 All workers must take every precaution to prevent loss and damage by fire. FIBOCO is responsible for ensuring that a current fire protection plan is in place and conforms to applicable laws and regulations.
- 3.10.2 Any work activity that produces sparks or open flame is considered to be Hot Work. As first consideration all Hot Work shall be performed off of Railroad property, if possible. This work includes, but is not limited to any activity that creates; live flame, molten slag, sparks, metal cutting, welding, grinding, and using a cut-off saw for metal or dry concrete. The use of abrasive wheels to cut or grind and any type of welding or using a torch shall be considered Hot Work. Open warming fires are not allowed in any manner, shape or form.
- 3.10.3 If removal of the planned Hot Work activity from Railroad property is not possible FIBOCO is required to fill out the Hot Work Checklist (Exhibit P)
- 3.10.4 Prior to any Hot Work a job briefing must be conducted to discuss the following:
- a) Insure the CC has been advised of all proposed Hot Work activities.
 - b) Preparation of the Hot Work Checklist by the contractor and discussion of roles and responsibilities including assignment of the Fire Watch person.
 - c) Remove all combustible material within 50 feet of the Hot Work area.
 - d) Review of the risk factors identified in the fire risk assessment and the application of the preventive measures required.
 - e) Fire prevention plan detailed in Railroad Emergency Response Form (Refer to Exhibit R) to be used in case of fire.
 - f) Review of the evacuation routes from the work site.
 - g) Review of the applicable emergency response plan.
- 3.10.5 Every effort should be made to extinguish a fire without endangering the safety of workers. Report promptly to RMCC any fire seen on or near the right of way, unless the fire is being controlled.
- 3.10.6 Fires that get out of control must be reported to local fire/emergency personnel and RMCC (888-877-7267). The area must be evacuated using the route detailed in the job briefing. Others in the immediate area also must be alerted.
- 3.10.7 Do not place gasoline or other combustible materials, including oxygen and acetylene, in a bus or truck compartment occupied by the driver or other persons. Do not transport gasoline or other combustibles in an automobile trunk, except in an emergency and then only in an approved container secured against movement.

3.11 WORK EQUIPMENT

- 3.11.1 Equipment operators must be properly trained and qualified before operating equipment on Railroad right-of-way, and must operate equipment in a safe, skillful and reliable manner.
- 3.11.2 Keep equipment in safe and good working condition. Use appropriate equipment for each task and operate all equipment per the manufacturers' instructions.
- 3.11.3 Do not engage in reckless operation of vehicles while on the Railroad's right-of-way. The speed limit on right-of-way roads is 15 mph (24 km/h) or less as conditions warrant. Offenders may be asked to leave the Railroad's right-of-way by any Railroad employee or representative observing unsafe behavior.
- 3.11.4 Audible backup warning devices are required on all heavy equipment. Vehicle headlights are to be illuminated while in operation on Railroad right-of-way.
- 3.11.5 Fire extinguishers are required on all heavy equipment and work vehicles.
- 3.11.6 At the end of each work day secure all equipment. Position front buckets and outriggers on the ground, prevent run-away situations and remove keys.
- 3.11.7 **NEVER** move equipment across the tracks except at established road crossings. Tracked equipment will require the supervision of a Railroad flagger any time Railroad tracks are crossed, including private road crossings.
- 3.11.8 **NEVER** move equipment across Railroad bridges or through tunnels.
- 3.11.9 Passengers in moving vehicles are required to be seated on actual seats in enclosed vehicles with seat belts fastened. Do not project body parts beyond the sides or rear of the vehicle. Do not transport passengers in truck beds. These requirements include transporting people on heavy equipment.
- 3.11.10 Use of equipment such as front loaders and backhoes to raise or lower people is strictly forbidden.
- 3.11.11 Escort outside company personnel (such as concrete truck operators) on and off the Railroad's right-of-way. It is the responsibility of the FIBOCO to arrange such escorts.
- 3.11.12 Use of any equipment that is outside 25 feet (7.62 meters) from centerline of nearest track, that has the capability to reach within [the Red Zone] 25 feet (7.62 meters) of the centerline of nearest track, must be coordinated with the CC.

3.12 WORKING NEAR POWER LINES

- 3.12.1 When performing work near electrical power lines, the clearance shown below must be maintained between personnel, their tools and equipment, and the nearest power line. When booms are used in the vicinity of power lines, Rule 78.7, Booms Near Power Lines, applies.

Operating Voltage Distance in Feet

0-5,000 - 4 Feet
5,000-15,500 - 6 Feet
15,500-25,000 - 7-1/2 Feet
25,000-35,000 9
35,000-50,000 12

Note: For voltages over 50,000 volts, add 1.2 inch for each KV (1,000 volts).

- 3.12.2 Measuring Overhead Clearance - A qualified person is required to measure overhead clearances using the proper instruments. Do not use steel or cloth tapes, ropes or strings to measure overhead clearance.
- 3.12.3 Booms Near Power Lines - Do not operate booms over power lines at any time. Do not operate them under power lines unless proper clearance is maintained. If proper clearance cannot be maintained, shut off the power and ground power lines before performing work.
- 3.12.4 Proper Clearances - If booms must be operated near energized lines, the following clearances must be maintained:
- a) Lines rated 50 KV (50,000 Volts) or less, minimum clearance between the lines and any part of the crane or load must be 10 feet.
 - b) Lines rated over 50 KV (50,000 Volts) and less than 170 KV (170,000 Volts), minimum clearance between the lines and any part of the crane or load must be 15 feet.
 - c) Lines rated over 170 KV (170,000 Volts), minimum clearance between the lines and any part of the crane or load must be 15 feet plus 1/2 inch per KV in excess of 170 KV (170,000 Volts).
 - d) When in transit, with no load and boom lowered, the equipment clearance must be a minimum of 8 feet for voltages less than 15 KV and 10 feet for voltages 15 to 50 KV.
 - e) For voltages 50 to 470 KV, the clearance must be increased 1/2 inch per KV in excess of 50 KV.
 - f) A groundman must be designated to observe equipment clearance and give timely warning for all operations when it is difficult for the operator to observe clearance.

3.13 TRENCHES AND EXCAVATIONS

Prior to the start of any trenching or excavations; a "Competent Person" as defined by the OSHA guidelines must be designated to insure compliance with the proper trenching standards.

- 3.13.1 Use shoring conforming to the most restrictive of state, OSHA, or Railroad standards in all excavations where required. Refer to OSHA standards in 29 CFR XVII Paragraph 1926.650 and the Railroad's Chief Engineer Instruction #124.0. Refer to Exhibit I.
- 3.13.2 When excavation work will be within the Railroad's right-of-way, shoring plans and other required material must be submitted to the VPE Representative for approval prior to any construction. Any excavation/hole less than 15' (4.57 meters) of centerline of nearest track must be filled or properly shored prior to any train passing. Refer to Exhibit I.
- 3.13.3 Avoid the need for workers to be in trenches whenever possible. Always comply with OSHA trench safety requirements when workers must enter an excavation for any reason. Any entry or use of confined space will require compliance to OSHA Standard 29 C.F.R. 1910.146.
- 3.13.4 Maintain escape routes, using foot walks or ladders meeting appropriate specifications, in all excavations to allow safe access to the excavators.
- 3.13.5 NEVER leave excavations, including trenches, unattended or unprotected. Fence, fill or guard each site prior to leaving. See Section 3.9 - Construction.
- 3.13.6 Monitor shored trenches and excavations continuously during work for signs of instability and failure. See Exhibit Q.
- 3.13.7 Always have at least two employees on site during work in an excavation.
- 3.13.8 NEVER work closer than 4 feet (1.22 meters) of the nearest rail without following **ON TRACK SAFETY** procedures. Although you must have a flagger with you in these circumstances you must also comply with **ON TRACK SAFETY** procedures.
- 3.13.9 DO NOT TAKE SHORT CUTS!!!

3.14 TRENCHLESS INSTALLATION OF FIBER SYSTEMS

- 3.14.1 Submit plans for all under-track bores on the Railroad's right-of-way to the VPE Representative for approval. Detail the following on the plans:

- a) Boring methods and equipment;
- b) Depth(s) of the fiber system;
- c) Locations of bore pits relative to centerline of nearest track;
- d) Casing specifications.

3.14.2 An extensive geotechnical analysis may be required to verify that Railroad tracks will not be affected by the proposed bore. It is the responsibility of the FIBOCO or its contractor to provide such an analysis at the Railroad's request.

3.14.3 All bores are subject to federal, state and/or local regulations

3.14.4 The location of the bore pit must not conflict with Railroad facilities. This may require designing a longer than normal bore when crossing roads, in order to avoid signal facilities.

3.14.5 Ultimate approval and direction of the boring process rests with the CC. The CC has the authority to delay the operation or establish additional requirements based on site characteristics.

3.14.6 Under-track bores are subject to the following requirements:

- a) Keep track bores under mainline tracks to a minimum.
- b) Design track bores to be greater than 150 feet (45.72 meters) from the nearest bridge, culvert, road crossing, track switch (Refer to Exhibit H), building or other major structure.
- c) Design bore pits to be a minimum of 30 feet (9.14 meters) from centerline of nearest track when measured at right angles to the track. Refer to Exhibit E. In addition, never locate bore pits in the slope of a cut or fill section of the roadbed. Keep the bore pit size to a minimum. See Section 3. 12 - Trenches and Excavations.
- d) All under track bores are to be at 90 degrees. When using a directional bore, a 60 degree angle or greater may be used, at the discretion of the CC, if justified due to the right-of-way or terrain constraints. Refer to Exhibit E.
- e) Pull back methods may use mandrels up to one and one-half times the diameter of the casing, up to a casing diameter of 12 inches (304.8 millimeters).
- f) Any parallel-to-track bore that is made in either a cut bank or fill section will be located a minimum of 60 inches (1.52 meters) below the toe of the ballast section or natural ground, or 84 inches (2.13 meters) below the base of rail, whichever is lower. Refer to Exhibit J.
- g) Casing pipe is required on all under track bores involving multiple duct systems.
- h) The bore plan should show the bore path profile. A bore plan or logbook must be kept with the boring equipment and provided to the CC or other Railroad employee when requested.

- i) An under track bore will not simultaneously cross the track(s) and an at-grade road crossing.

3.14.7 **Mini-Directional and Directional bores/drilling are permissible.** Directional bores will be considered for under-track and parallel-to-track bores on a case-by-case basis, subject to these additional constraints:

- a) Under-track bores are installed a minimum depth of twelve feet (3.66 meters) below the base of rail, or 60 inches (1.52 meters) below the natural ground line, whichever is greater. Refer to Exhibit N.
- b) Slurry use is kept at a minimum and only used for head lubrication and/or spoils return. Calculate anticipated slurry use and monitor slurry use during the bore operation to determine slurry loss into the surrounding soil. A bentonite slurry is required and pressures must be controlled for the type of soil being bored. All voids created during the bore operation must be grouted. Using slurry other than bentonite requires CC approval, and must not leave voids or contaminant the soil.
- c) The maximum size of the installed product is 12 inches (304.8 millimeters).
- d) Bentonite slurry should be used to seal the hole with a minimum of 95% return.
- e) Bore stems and cutting heads may have to be left in the ground if they cannot be retrieved through the bore hole. Open excavation to retrieve the parts may not be possible.
- f) If an under track bore is at a depth of 12' (3.66 meters) below base of rail or more, a single duct system can be pulled back without a casing pipe. The pull back hole must be as small as possible and is not to exceed one and one half times the diameter of the finished duct. Exceptions must be approved by the CC.
- g) The design of the bore shall allow the path to be at a zero slope for a minimum of 30 feet (9.14 meters) from the centerline of the track, 2 feet (61 centimeters) from the toe of slope and 3 feet (91 centimeters) beyond the ditch, whichever is greater.
- h) The bore path of a parallel bore shall be at a zero slope for a minimum of the width of the facility causing the bore. Facilities shall include, but are not limited to, roads, culverts, ditches, streams, rivers, other utilities and tracks. The bore shall be extended, when practical, to avoid conflict with signal upgrades.
- i) A bore profile for the proposed bore must be included with the design plans, along with the entry angle.
- j) Follow recommended machine mixing rates when adding bentonite to the drilling fluid.
- k) Be sure any HDPE duct still on the reel is secured, when cutting, to prevent movement.
- l) Any annular space must be properly grouted.

3.14.8 **Dry Bores:** Generally accepted dry installation methods for under-track or parallel-to-track bores include:

- a) Jacking the casing.
- b) Dry auger boring.
- c) Simple rod punching with pull back of casing.
- d) Directional boring without use of any liquid including control and lubrication of the cutting head.

3.14.9 When using a dry bore method, locate the fiber system a minimum of 60 inches (1.52 meters) below the base of rail or natural ground, whichever is greatest. Encase in galvanized steel pipe or black iron pipe [Specified Minimum Yield Strength of 35,000 psi (241,318 kPa) or above] all fiber system lines under tracks in a single casing. Use of plastic pipe that conforms to the same specifications to eliminate the Hot Work process is suggested. Extend the casing a minimum of 30 feet (9.14 meters) from centerline of the track, measured perpendicular to the track, or longer, to stay out of cuts and/or fills. The casing shall be extended a minimum of 2 feet (61 centimeters) beyond the toe of slope or 3 feet (.91 meters) beyond the ditch.

3.14.10 **Wet Bores:** Generally, wet bores are not allowed for installing Fiber Systems on the Railroad's right-of-way. Wet bores, or jetting, as used in this context refer to the use of liquids to displace soil.

3.14.11 **Other Bore Methods:** Generally, other methods of boring will be considered on a case-by-case basis. Special conditions such as rock drilling that require the use of high-pressure air or water are subject to all of the conditions of this section and will be evaluated as they occur. Blasting is not allowed.

3.15 HOUSEKEEPING

3.15.1 At the end of the day:

- a) Secure all equipment.
- b) Secure all open excavations.
- c) Clean up work sites and Railroad right-of-way. Remove trash from the property or arrange for proper disposal.
- d) Restore all disturbed ditches and culverts to water-carrying capability. This may, with Railroad approval, include culverts found during construction not previously identified or functioning.

3.15.2 Place all materials and equipment not in use at the outer limits of the Railroad's right-of-way. Make sure all material and equipment is secured and safe. Do not place materials or equipment:

- a) Closer than 25 feet (7.62 meters) from centerline of nearest track, or within 500 feet (152.40 meters) of a road crossing.
 - b) On Railroad right-of-way roads.
 - c) Where it might cause injury.
 - d) Where it might cause environmental damage.
 - e) Where it might interfere with Railroad operations.
- 3.15.3 Do not place air hoses, water lines, electrical cords, etc. over or under rails without specific permission from the Railroad flagger or CC.
- 3.15.4 Combustibles must be stored off of the Railroad's right-of-way. Do not leave containers, empty or full, unattended on the Railroad's right-of-way.
- 3.15.5 Do not obstruct sight distances at grade crossings with materials, equipment or personal vehicles. A minimum distance of 500 feet (152.4 meters) from road crossings must be maintained for stored materials and equipment.
- 3.15.6 Keep the Railroad's right-of-way roads clear and passable at all times.

3.16 BRIDGES AND ABOVE GROUND INSTALLATIONS

- 3.16.1 A Railroad flagger is required during any work on bridges and will need to be arranged for in advance. See Section 3.5 - Railroad Flagging/Protection.
- 3.16.2 Fall protection is required for work performed on all bridges and above ground installations. When working on bridges with existing track, the most restrictive of either FRA Bridge Worker Safety Regulations (49 CFR Part 214) or the Railroad's Chief Engineer Instruction #122.0 will apply. Work on all other bridges and structures on the Railroad's right-of-way is governed by the most restrictive of OSHA (29 CFR Parts 1910 and 1926), the Railroad's Chief Engineer Instruction #133.0, or state regulations.
- 3.16.3 Contractors performing work on bridges and above ground facilities on or over Railroad property must submit written documentation certifying their employees have received proper training in fall protection, prior to engaging in work on Railroad property. The contractor must further satisfy the CC or his representative that proper equipment and compliance with these standards will be adhered to on the job site.
- 3.16.4 Crossing a bridge is strictly prohibited without a Railroad representative (Refer to Section 3.15.1). Use the foot-walk when crossing bridges and always watch for trains. However, if no foot-walk is available, walk between the rails, with all appropriate caution.
- 3.16.5 Place materials and equipment in a location approved by the CC and plan for quick evacuation when so advised by the Railroad flagger or bridge operator.

- 3.16.6 No work is allowed on or around bridges when trains approach or pass.
- 3.16.7 Obtain daily permission from the CC to climb the Railroad's poles to hang the fiber system. Ensure all power lines on the poles have been de-energized. Check the poles for structural integrity before climbing. Use climbing equipment conforming to OSHA regulations.
- 3.16.8 Any installation crossing the Railroad track, must comply with these standards. In addition, where federal, state, local, and/or public utilities commission laws and regulations meet or exceed the requirements of the Railroad, those requirements will apply. (Refer to Exhibit L)

3.17 WEATHER

- 3.17.1 Keep all employees informed of current weather conditions.
- 3.17.2 Stay alert for possible high water conditions.
- 3.17.3 During severe weather conditions:
- a) Be prepared to take cover in the event of a tornado.
 - b) DO NOT work while lightning is occurring.
- 3.17.4 If storm conditions arise unexpectedly, ensure equipment is clear of tracks and secured before seeking cover.
- 3.17.5 Stay away from Railroad tracks when visibility is poor, such as during fog or blizzard conditions.

3.18 REPEATER STATIONS (REGENS)

The placement of regens on Railroad Right-of-Way may require a Railroad Real Estate department permit.

- 3.18.1 Regen design drawings must include the information as detailed in Section 3.8 Drawings, as well as the following:
- a) A plan view clearly outlining the occupied area or “footprint” of the site, including, but not limited to building size and access, fenced perimeter, exclusive use access roads, parking areas and the running line.
 - b) Profile views detailing soil removal and the limits of all cuts and/or fills, required to construct the site, conforming to environmental requirements.
 - c) Cross-sections showing how site drainage is handled.

- d)** Indication of all details concerning the site, such as concrete pad depth, distance from centerline of nearest track, all appurtenances, and distance from all road crossings.
- 3.18.2 Include with the power supply detail the following: voltages, distances relative to the mainline and other structures, overhead clearances and below ground dimensions.
- 3.18.3 Locate regens a safe distance from the nearest grade crossing. The governing minimum distance is the most stringent of either: 1) Local, state, or AASHTO clear sight distance requirements for grade crossings, or 2) 500 feet (152.4 meters). Refer to Exhibit F. These requirements could vary due to train and vehicle speeds at the crossings.
- 3.18.4 Do not locate regens under signal, communication, or power lines.
- 3.18.5 Locate regens a minimum of 50 feet (15.24 meters) from centerline of the nearest track to the nearest element of the regen facility, and avoid placement adjacent to track curves. Refer to Exhibit F.
- 3.18.6 Do not place regens where they may obstruct train signals or interfere with Railroad operations.
- 3.18.7 Regens may have to be located on private property to meet the requirements of this section.

4 DIG SAFELY – LOCATE ACCURATELY

- ❑ Call the Union Pacific Call Before You Dig Center at 1-800-336-9193
- ❑ Wait For The Site To Be Marked
- ❑ Respect All Markings
- ❑ Dig With Care

**Locate Accurately
Dig Safely.®**

Underground Safety and Facility Damage Prevention
"A Shared Responsibility"



**Know what's below.
Call before you dig.**

5 DOCUMENTATION

5.1 DESIGNER REQUIREMENTS

- 5.1.1 Ensure the designer of your fiber system gets a copy of these requirements as early as possible to avoid unnecessary delays. It is the intent that the information shown on the project construction drawings will easily convert to As Built drawings by incorporating the changes made during construction.
- 5.1.2 Construction drawings that do not have the proper Railroad engineering stationing ties result in unacceptable As Built drawings. If for any reason, construction plans are approved without the proper ties, it is the FIBOCO's responsibility to provide them prior to As Built drawing approval. Refer to Exhibit B, **UNION PACIFIC RAILROAD METHODOLOGY FOR EQUATING FIBER OPTIC CABLE LOCATIONS TO RAILROAD TRACK AND RIGHT-OF-WAY MAPS.**
- 5.1.3 All of the dimensions in this manual have been given in English units with the metric unit equivalents in parentheses. However, all drawings submitted for Railroad approval need to have dimensions given in English units only. All As Built drawings will be submitted at a scale of 1"=100' (2.54 cm = 30.48 meters) or 1"=400' (2.54 cm = 121.92 meters) in rural areas. An exception can be made for electronic media. Contact the VPE Representative in 5.1.10.
- 5.1.4 Include original drawing dates and revision dates on all revised drawings.
- 5.1.5 Include the following information on all construction plans and final As Built drawings:
- a) Alignment of the fiber system with Railroad engineering stationing at each running line change or Point of intersection (PI) including handholes, signs, and markers.
 - b) Depth of the fiber system, shown at each deviation of one foot (30 centimeters) or more.
 - c) Bridges (the Railroad engineering stationing shown is measured from inside the backwall of a bridge). Refer to Exhibit C.
 - d) Bridge attachments and their details.
 - e) Culverts.
 - f) Signals, signal houses, and other signal facilities.
 - g) All grade crossings, overhead viaducts, and underpasses, including name of the street (public or private) and Railroad mile marker designation.
 - h) All utility crossings (both underground and overhead), and all parallel utilities.
 - i) Rivers, fences, and pole lines.
 - j) Railroad right-of-way limits.
 - k) Railroad station names and mile markers.
 - l) All mainline switches and secondary tracks.
 - m) Number of fibers (fiber count) and number of ducts.

5.1.6 Include a separate detailed drawing for each regen station. Show all details of the site, referenced to the mainline track, such as:

- a) Building size and distance building is from all road crossings.
- b) Distance the regen building is from centerline of all adjacent tracks.
- c) Power supply required for the regen building, including locations relative to the mainline, voltages, above and below ground dimensions.
- d) Building access.
- e) Any other facility pertinent to the project.
- f) Location of fencing around the regen site, complete with dimensions.

5.1.7 Include the following additional information on construction drawings submitted to the Railroad:

- a) General notes along with the symbols and their meanings.
- b) A sheet showing all the special details.
- c) Small scale maps showing the overall fiber system route.
- d) Schematic showing regen sites.
- e) Sheet showing various methods of erosion control.
- f) Sheet showing details for backhoe trenching below a ditch, trench below a stream, direct burial for a ditch or creek crossing (plan and profile view).
- g) Sheet showing detail for placement of conduit in rock, including provisions for protecting Railroad ballast where it may be fouled by rock sawing operations.

5.1.8 Show all measurements of each of the above from and at right angles to the centerline of the nearest mainline track. Show on the drawing the distance to the next facility as measured along the centerline of the main track.

5.1.9 Note: Mile markers found in the field are representative of actual Mile Posts found on Railroad's right-of-way maps. These are intended to provide general locations of facilities for location by Railroad personnel. These mile markers are not accurately located on our maps and should not be used to establish Railroad stationing. Show them on your drawings for reference only.

5.1.10 Submit As Builts to:

Engineering – As Builts
Union Pacific Railroad Company
Mail Stop 0640
1400 Douglas Street
Omaha, NE 68179
(402) 544-3719 or (402) 544 3582

5.1.11 Submit As Builts no later than 90 days after the completion of the installation of the fiber system on the Railroad's right-of-way. The project is not complete until this is done.

6 MAINTENANCE

6.1 EMERGENCY MAINTENANCE

6.1.1 In the event that Emergency Work is required, the following procedures apply:

- a) **Call 1-800-336-9193, a Union Pacific 24-hour, 7-day CBUD Desk number.**
- b) Call the CC for emergency engineering approval. Railroad will determine inspector/flagger needs based on site conditions. (See Section 3.6)
- c) Perform emergency work only when appropriate flagging/inspection personnel are on site.
- d) Following the completion of emergency repairs to restore the fiber system to service, permanent restoration of the fiber system falls under the conditions of the following section.
- e) Prior Railroad notification of any excavation involving Railroad right-of-way must be provided.
- f) Any Railroad designated non-entry point due to dangerous or hazardous conditions must be strictly adhered to.

6.2 REGULAR MAINTENANCE

6.2.1 Notify the Railroad's CBUD desk by telephone at 1-800-336-9193 prior to entering the Railroad's right-of-way to repair or maintain the fiber system. This call will facilitate the performance of your work by ensuring that Railroad personnel and other communication companies affected by your work receive notification of your work.

6.2.2 The methods and procedures of all maintenance and repair work are subject to the consent and approval of the VPE Representative. Submit to the VPE Representative for approval plans for any work not previously detailed in the Approved Plans. Include (as applicable) drawings showing the plan, elevation, details, Railroad engineering stationing and methods of the proposed construction, installation, maintenance, repair, replacement, or other work.

6.2.3 Coordinate the scheduled start dates of all work with the CC. Maintenance and repair schedules are subject to the availability of Railroad CC's, flaggers, signal maintainers, and other Railroad personnel necessary to ensure that the work is performed safely and without disruption to Railroad operations.

6.2.4 FIBOCO crew locations and the number of crews may be restricted depending on Railroad flagger availability, job site access and adequate radio communications.

- 6.2.5 Ensure that all representatives and employees of the FIBOCO and its contractor have been safety trained by a representative of the Union Pacific Fiber Optic Group and display their annual "Safety Trained" stickers on their hard hats.
- 6.2.6 Follow the construction guidelines in Section 3.9 - Construction for any repair or maintenance work involving alteration of the fiber system.
- 6.2.7 Never allow work to disrupt rail operations, including but not limited to, train operations, facilities maintenance, and communications.
- 6.2.8 Do not store or place equipment, supplies, materials, tools, or other items within 25 feet (7.62 meters) of the centerline of nearest track unless the CC approves such placement.
- 6.2.9 Begin clean-up and restoration immediately upon completion of maintenance operations. Restore the Railroad's right-of-way to as good as or better condition as prior to the maintenance being performed.
- 6.2.10 To protect other utilities, prevent missed locates, and maintain current, meaningful location data, remove abandoned fiber optic cable system facilities, see Section 3.9.36 - Construction. If any component of the fiber system is not removed, maintain records of the location of such abandoned fiber system facilities.
- 6.2.11 When maintenance requires additional facilities, such as handholes, manholes, regens, conduits or any right-of-way disturbance, Railroad engineering approval is required per Section 2.
- 6.2.12 Notify the CC prior to setting up your maintenance route patrols. Make sure the CC is aware of any frequency or schedule changes, including emergency patrols. Be aware that weather conditions, increased train traffic, locks, security and access roads may affect your patrol.

7 DEFINITIONS

811: The national One-Call phone number.

Aerial Marker Sign: A large sign, typically in the shape of a "V" that can be observed from the air, used for aerial location and inspection of the fiber system.

As Built: A drawing, depicting the actual location of the fiber system in relation to the Railroad, having proper documentation for approval by the VPE Representative.

Ballast: The rock that supports the track and ties. This rock is groomed to keep the track in place, drain water away from the track, and to distribute the weight of trains to surrounding soil. DO NOT DISTURB.

Branch line: A secondary route to the Railroad that, for safety reasons, should be treated as a primary line.

Bridge Attachment: A Railroad-approved method of affixing the fiber system to one of the Railroad's bridges.

Bridge Backwall: The topmost portion of an abutment above the elevation of the bridge bearing, functioning primarily as a retaining wall for the roadbed.

Bridge Bearing: The contact area and/or physical connection between bridge girders and bridge abutments or piers (Exhibit C).

Call Before You Dig (CBUD): A Union Pacific 24-hour by 7-day communication center, available through the 1-800-336-9193 number, to assist in protecting, documenting and notifying callers of authorized fiber optic facilities installed within Railroad right-of-way. The center is to be used by anyone proposing to dig on Railroad right-of-way.

Casing: A secondary, independent, rigid covering used to protect the fiber system and the roadbed when installed under the Railroad's tracks.

Centerline of Track: An imaginary line, that runs down the center of the two rails of a track.

Common Ground: A study titled *Common Ground: Study of One-Call Systems and Damage Prevention Best Practices*, authorized by the Transportation Equity Act (TEA 21), Public Law 105-178 signed into law on June 9, 1998 through the United States Department of Transportation, Research and Special Programs Administration Office of Pipeline Safety and the One-Call Systems Study.

Competent Person: Means one who is capable of identifying existing and predictable hazards in the surroundings, or working conditions which are unsanitary, hazardous, or dangerous, and who has authorization to take prompt corrective measures to eliminate them. (29 CFR 1926.32(f) To be a "Competent Person", a person must have training in, and be knowledgeable about, soils analysis, the use of protective systems and the requirements of this standard.

Conduit: An independent tube or duct system used to house one or more fiber optic cables.

Confined Space: A space that is large enough and so configured that an individual can bodily enter and perform assigned work. The space has limited or restricted means for entry or exit and is not designed for continuous individual occupancy. This would include but not limited to tanks, vessels, silos, storage bins, hoppers, vaults and pits.

Construction Coordinator (CC): A Union Pacific Railroad Company employee or representative of the Railroad who serves as the liaison between the FIBOCO and the Railroad.

Contractor: Any FIBOCO authorized worker, other than a Railroad employee, who is working on Railroad property as a FIBOCO representative or agent.

Cooper E-80: A loading specification as defined in the AREMA Manual for Railway Engineering

Cut: A section of earth that has been excavated to allow construction of the Railroad's track where an embankment remains on one or both sides of the track.

Derailment: A potentially dangerous condition, whereby Railroad cars or engines leave the tracks.

Dig Ticket: Issued by Union Pacific's CBUD upon timely communication by an excavator/designer requesting its intent to excavate for any reason along Railroad Property.

Directional Bore: A method that controls the direction of boring and eliminates conventional bore pits allowing for a longer bore length than conventional methods.

Dispatcher: A Railroad employee responsible for authorizing all track use, including train movements and maintenance.

Drawings: A graphic representation of proposed fiber routes, detailed construction plans, or As Builts.

Employee In Charge (EIC): The Railroad Employee on site who is responsible for providing positive train protection for employees or contractors working on or near the tracks.

Emergency Response Plan: Develop basic preparedness steps developed to handle the anticipated emergencies at your work site. Although Emergency Response plans are not meant to be all-inclusive, they should provide appropriate guidance on what to do in an emergency for the work being performed.

Encased: A term used to indicate that the fiber system has a secondary, independent, protective covering.

Engine: The vehicle used to pull Railroad cars. Typically this refers to the locomotive, but can be any self propelled vehicle.

Excavation: Any removal of earth to allow installation of the fiber system. Any excavation, no matter how large or small, requires a telephone call to Union Pacific's CBUD desk at 1-800-336-9193.

Fall Protection: A requirement by the FRA and Railroad, that ensures training and protection for work performed on any bridge structure that is at a height of 10 feet (3.05 meters) or more above water or ground, and/or while working at a height of 10 feet (3.05 meters) or more.

Fiber Optic Company (FIBOCO): The facility owner or company that enters into the agreement with the Railroad and has the ultimate responsibility for all aspects of construction, maintenance and operation of the fiber system. This responsibility includes any contractor, employee, or consultant hired by that company.

Fiber Optic Database: Railroad's electronic CBUD database.

Fiber System: A telecommunications transmission system and its appurtenances.

Fill: A section of earth built up to support the Railroad's track structure.

Fire Prevention: Before beginning any Hot Work, completion of the Hot Work Checklist is required. (See Section 3.1.1.11) A thorough job briefing must be conducted to discuss the fire preventive measures to be taken in accordance with appropriate fire suppression methods that would be utilized in case of a fire. The job briefing must also include a review of the Emergency Response Plan in effect for the specific work location. The Emergency Response Plan must detail the method of contacting local fire/emergency personnel, the train dispatcher and Risk Management Control Center (RMCC). The Emergency Response Plan must also include the evacuation route to be followed in case of a wildfire.

Flagger: A Railroad employee, working at the direction of the CC, who provides for the safe use of the Railroad's right-of-way.

Foul the Ballast: Anything that contaminates the ballast section of the roadbed and inhibits the ballast from supporting the track, draining water, or suppressing weed growth.

Foul the Track: Any obstruction that renders the track system unsafe for train passage.

Grout: A cementitious or epoxy substance used to repair concrete, fill holes in concrete, or to anchor bolts, rods, etc., in concrete. Grout must be approved by the VPE Representative prior to use.

HS-20: A loading specification as defined in the AASHTO Standard Specification for Highway Bridges

Hot Work: Considered to be any work activity that produces sparks or open flame. This work includes, but is not limited to, using abrasive wheels to cut or grind, any type of welding and using a torch. (Refer to the Section 3.10)

Hy-rail: A vehicle, typically driven on highways, that has specially manufactured attachments, that allows the vehicle to travel on Railroad tracks. They are viewed as trains, and only authorized Railroad personnel may operate them.

Industry Track: A secondary track designated to allow access to industries along the main track.

Innerduct: Flexible independent tubes inside a conduit.

Job Site: Any area where work is performed, where materials and equipment are stored, or which employees access during the fiber project.

Locate: The determination in the field of the depth and horizontal position of fiber optic systems or other underground utilities.

Mainline/Main Track: The primary track used by trains. Some of the routes have double, triple, and quadruple mainline tracks.

Marker signs: Signs placed by the FIBOCO indicate a fiber system is in the area, provide a 1-800 number for information regarding the system, and provide the FIBOCO's name.

Mile markers: Field indicators of approximate distance from a specific point on the Railroad system used for approximate locations of Railroad Facilities. They are not to be used for field surveys.

Mile Post: A theoretical breakdown of rail lines into mile-long segments.

On Track Safety: A set of safety rules, developed and promulgated by the FRA, that must be complied with to work on or near Railroad property. Specific training and obedience to these rules is a requirement of the FRA. Where Railroad rules are more

- stringent, those rules shall apply. Significant fines and the loss of your permission to work on Railroad right-of-way can result from the violation of these rules.
- Point of Intersection:** A point on a map or drawing indicating the location of a curve in the fiber system. The point is the vertex of an angle formed by the intersection of two sequential, non-parallel segments of the fiber system.
- Railroad:** Union Pacific Railroad Company and its Railroad affiliates and subsidiaries.
- Railroad Car:** Any vehicle that can move on the track structure and is not self-propelled.
- Remote Controlled Locomotives (RCL):** A locomotive controlled remotely by a radio transmitter and receiver by a person not physically located at the controls within the confines of the locomotive cab.
- Red Zone:** The area within 4 feet of any track, or any physical position which places the person in a life-threatening situation. This includes working around derailments, highway crossings and equipment work zones.
- Regen:** An acronym for a regeneration facility. Typically a building along the fiber system route housing equipment.
- Regen Facility:** The regen building and all of its appurtenances such as fences, signs, posts, or other physical features.
- Right-of-Way:** Land that the Railroad owns or owns an interest in that contains facilities for train operations and which is utilized in the performance of the fiber project.
- Response Management Communication Center (RMCC):** A Union Pacific 24-hour by 7-day communication center, staffed by the Railroad to handle any emergency situation, including but not limited to, an ability to stop trains and notify emergency personnel. The 1-888-UPRR COP (1-888-877-7267) number should be used to report any unsafe condition or emergency while on Railroad right-of-way.
- Roadbed:** The graded area beneath and on either side of the track structure that provides support and drainage of the track.
- Running Line:** Proposed or existing location of the fiber optic system.
- Safety Training:** A session conducted by a qualified Railroad representative at which Railroad rules and regulations are presented and discussed.
- Safety Sticker:** An emblem that indicates completion of Railroad Safety Training. The non-transferable "Safety Trained" emblem is to be placed on each individual's hard hat so it is visible when working on the Railroad's right-of-way.
- Shoring:** Methods and materials used to prevent the collapse of the earthen walls of excavations.
- Siding:** A secondary track used for the passing of trains on single-track routes.
- Signal:** A Railroad facility used to provide for the safe movement of trains and protection at crossings. The facilities include gates, lights, wires, bungalows, and all ancillary devices supporting these operations.
- Splice:** A point in the fiber optic system running line where cables are fused together to create a continuous system.
- Spur Track:** A secondary track designed to allow access to industries along the main track.
- Switch:** A moveable track device that allows trains to transfer from one track to another, encompassing the distance from the point of switch to the point of frog. (See Exhibit H).

Tracks: The rails, ties, and ballast that compose the traveling surface used by trains.

Track Structure: The rails, ties, ballast, and roadbed that compose the traveling surface used by trains.

Trains: One or more engines coupled together, with or without Railroad car(s) that use the Railroad's tracks.

Train Movement: Any motion of engines and/or Railroad car(s) over the Railroad's tracks.

Trench: A narrow section of earth removed to allow installation of the fiber system.

Valuation Map: A Railroad map depicting the Railroad's facilities and engineering stationing.

Wet Bores (Jetting): Are bores that use liquid to displace soil. (Refer to Section 3.14.10)

Yard: A collection of secondary tracks used to store equipment (Railroad car(s), engines, maintenance machines, etc.), assemble or disassemble trains, and/or conduct other Railroad operations.

8 ABBREVIATIONS

AASHTO: American Association of State Highway and Transportation Officials

ANSI: American National Standards Institute

AREMA: American Railway Engineering and Maintenance-of-Way Association

ASTM: American Society for Testing and Material

BIP: Black Iron Pipe

Br: Bridge

CBUD: Call Before You Dig

CC: Construction Coordinator

CE: Chief Engineer

CG: Common Ground

CIP: Corrugated Iron Pipe

CL/Trk: Center Line of Track

CMP: Corrugated Metal Pipe

Conc: Concrete

C/L: Center Line

EIC: Employee In Charge

FIBOCO: An acronym for the fiber optic company

FRA: Federal Railroad Administration

F/L: Flow Line

GSP: Galvanized Steel Pipe

HDPE: High Density Polyethylene Plastic

HH: Handhole

Lt: Left

MH: Manhole

MM: Mile marker

MP: Mile Post

MUV: Multi-Purpose Utility Vehicle

OSHA: Occupational Health & Safety Administration

PI: Point of Intersection

PVC: Polyvinyl Chloride Plastic

RCL: Remote Control Locomotive

Rt: Right

R/L: Running Line

R/W: Right-of-Way

R-O-W: Right-of-Way

RMCC: Response Management Communication Center

VPE Representative: The Railroad's Vice-President of Engineering or authorized representative.

Xing: Crossing

9 APPENDIX

9.1 List of Exhibits:

- A) UNION PACIFIC RAILROAD SAFETY, ASSET UTILIZATION & FIBER OPTIC TECHNOLOGY GROUP LIST**
- B) UNION PACIFIC RAILROAD METHODOLOGY FOR EQUATING FIBER OPTIC CABLE LOCATIONS TO RAILROAD TRACK AND RIGHT-OF-WAY MAPS**
- C) BRIDGE DEFINITION**
- D) CABLE DEPTH AROUND CULVERTS AND DITCHES**
- E) TYPICAL RAILROAD BORE AND PIT LOCATION**
- F) REGEN LOCATION**
- G) CONVENTIONAL FILL INSTALLATION**
- H) STANDARD TURNOUT (TRACK SWITCH)**
- I) GENERAL SHORING REQUIREMENTS**
- J) DIRECTIONAL BORE FILL INSTALLATION**
- K) INSTALLATION ON TOP OF CUT**
- L) STANDARD FOR MINIMUM CLEARANCES**
- M) ROCK TRENCH**
- N) TYPICAL RAILROAD DIRECTIONAL BORE DEPTH**
- O) HANDHOLE LOCATION**
- P) HOT WORK CHECKLIST**
- Q) TRENCH SAFETY INSPECTION CHECKLIST**
- R) RAILROAD EMERGENCY RESPONSE FORM**

9.2 References:

**Current Common Ground Alliance (CGA) Best Practices General Guide
For Additional Information On The Common Ground Alliance, Or Learn How To
Become A Member Visit The CGA Web Site At
www.Commongroundalliance.Com.**

10 INDEX

Accidents.....	5, 7, 8, 9
As Builts.....	44, 45
Bores	22, 23, 32, 34, 45, 48
Bridge.....	36, 40, 44, 49
CBUD	14, 19, 42, 45
CC (Construction Coordinator)...	3, 9, 12, 19, 20, 22, 24, 25, 26, 30, 33, 36, 42, 43, 45, 46, 49
Ditches	19, 24, 35
EIC	45, 49
Excavations.....	15, 23, 32, 33
FIRE PREVENTION.....	29
Flagger	12, 46
Flagging/Protection.....	11, 36
FRA.....	36, 45, 46, 49
HOT WORK.....	29
Injuries	8, 9
On Track Safety	5, 6, 11, 13, 46
OSHA.....	21, 23, 25, 32, 36, 49
RCL.....	47
Regen	37, 38, 47
Right-of-way..	3, 5, 6, 7, 8, 9, 11, 12, 13, 14, 15, 17, 19, 20, 21, 22, 24, 25, 26, 30, 32, 33, 35, 36, 40, 41, 42, 43, 46, 47
Shoring.....	15, 22, 23, 32, 47
Signals.....	8, 18, 38, 40
Track structure	11, 22, 32, 45, 47
Trenching	23, 24, 32, 41, 48
Wet Bores.....	21, 35, 48

11 Notes

ILLUSTRATION OF METHODOLOGY

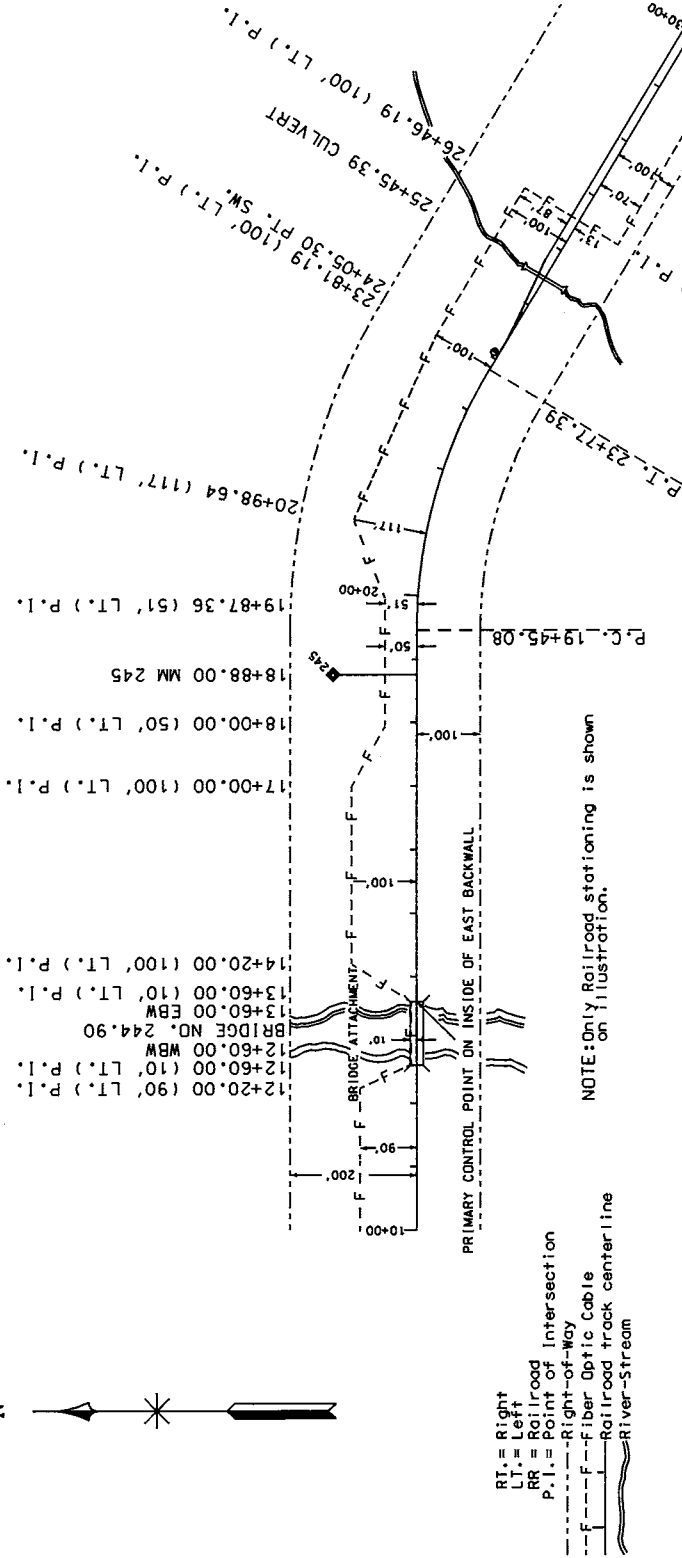

NOTE: Only Railroad stationing is shown on illustration.

Key Points:

- Each running line change or point of intersection, facility, or point of interest must be located and labeled with the appropriate RR engineering stationing.
- All measurements of running line changes and fiber facilities must be shown from and at right angles to the centerline of main track. The distance to the next running line change or facility must be shown as measured along the centerline of main track and that distance shown on the map. If distances are measured from a side track, track centers to main track must also be measured.
- RR stationing must be shown for each point of intersection or running line change, and for each fiber optic facility. These items must be measured from the closest approved RR control point.
- The RR engineering stationing is obtained by using copies of existing RR right-of-way maps or the data generated by Precision Measurement Vehicle, which will establish the stationing of RR approved control points and all measurements must be referenced to these control points.

— Primary control points should be used whenever possible.

Submittal Notes:

- The "as built" (plans) provided to the railroad may be in either straight-line or geometric form on reproducible media (paper, vellum, mylar etc.). The data can be supplemented by a DXF or Intergraph CAD file.
- If Fiber Company is using other than RR stationing, then an identity equating the RR stationing to the fiber stationing must be used. However, RR stationing must be shown as stated above.
- Items of interest, such as mile markers, should be shown on the "as built" for information only, and not used as control points to establish stationing.
- Items of interest such as rivers and roads should be shown on the "as built" with the applicable name or route number.

Items of Interest:
 The following items should be shown:
 - railroad mile markers
 - railroad station names
 - roads (public and private) (include name if available)
 - overhead viaducts
 - wires and pole lines
 - underground pipes
 - bridges and culverts
 - rivers, ditches, and canals
 - trackage and fences
 - right of way boundaries
 - state, county, and section lines

Approved Railroad Control Points:

All control points are measured at or from center of main track.

Primary Control Points:

- inside bridge backwalls
- centerline of culverts
- point of switch on mainline turnouts

Secondary Control Points:

- overhead viaducts
- underpasses
- signals
- buildings (within the R-O-W)

CAUTION:

Only control points that are verifiable on current Railroad maps are to be used.



Union Pacific RR

EXHIBIT B

METHODODOLOGY
 FOR EQUATING FIBER OPTIC
 CABLE LOCATIONS TO RAILROAD
 TRACK & RIGHT-OF-WAY MAPS

NO SCALE

PP. 12-5-11

TYPICAL CONCRETE BRIDGE

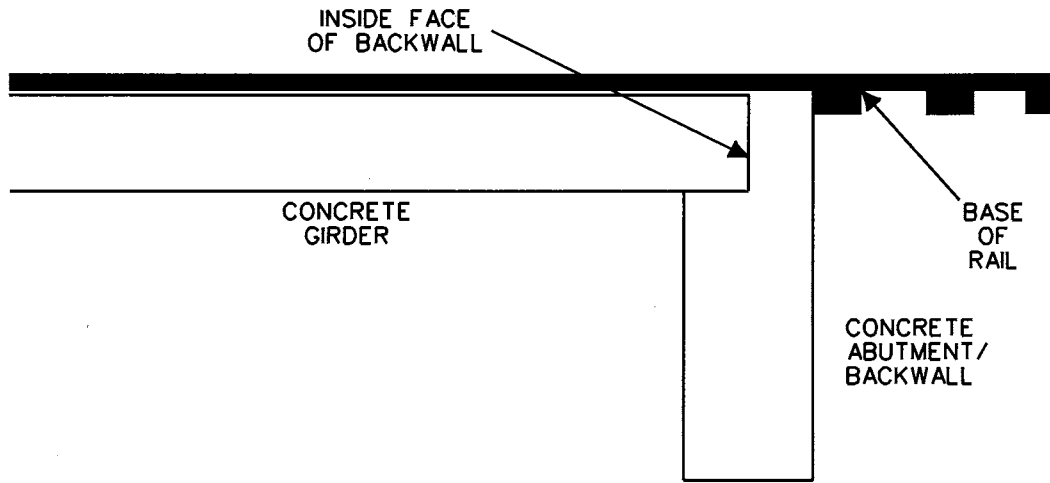

TYPICAL STEEL BRIDGE

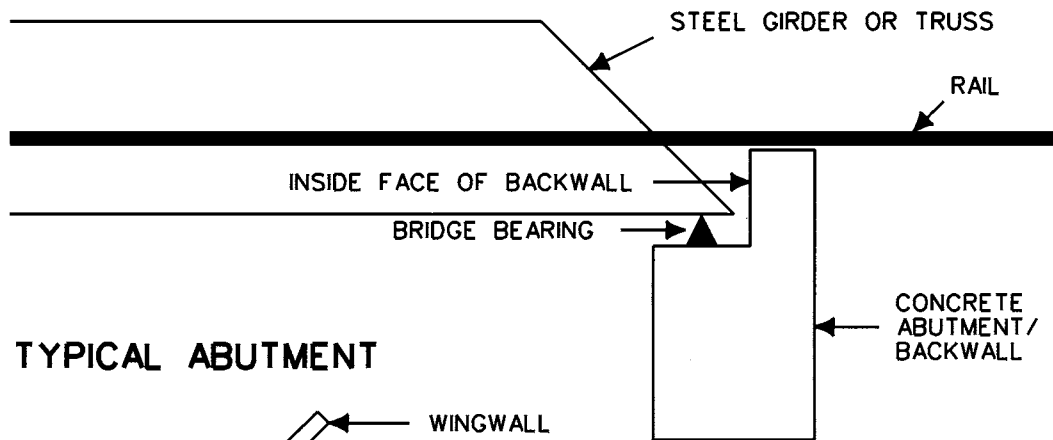

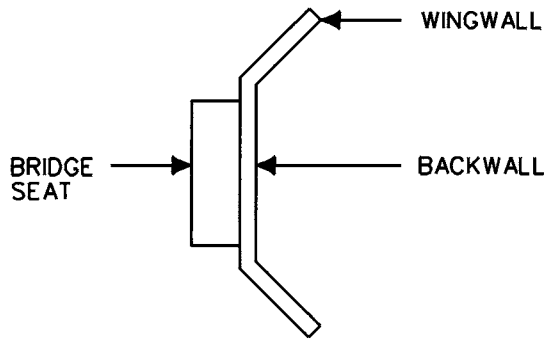

TYPICAL ABUTMENT

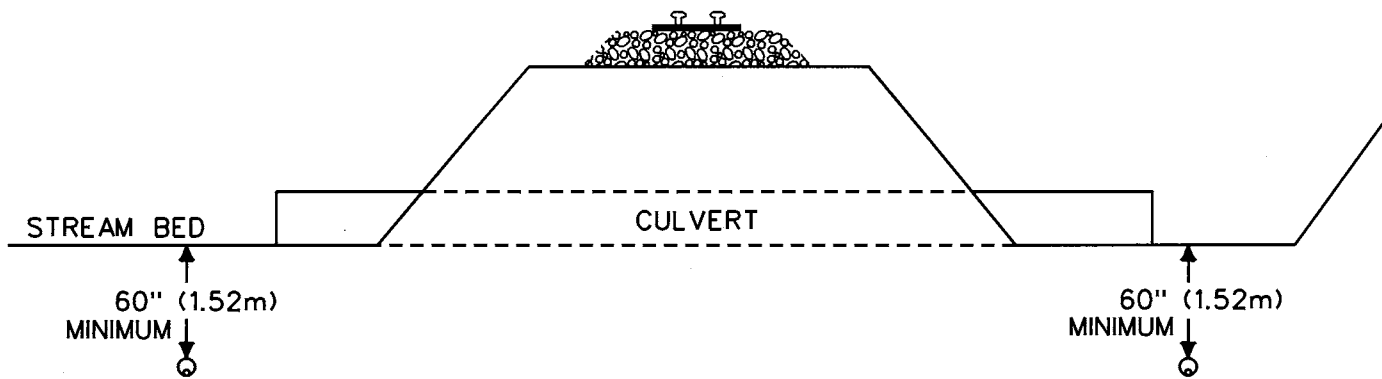
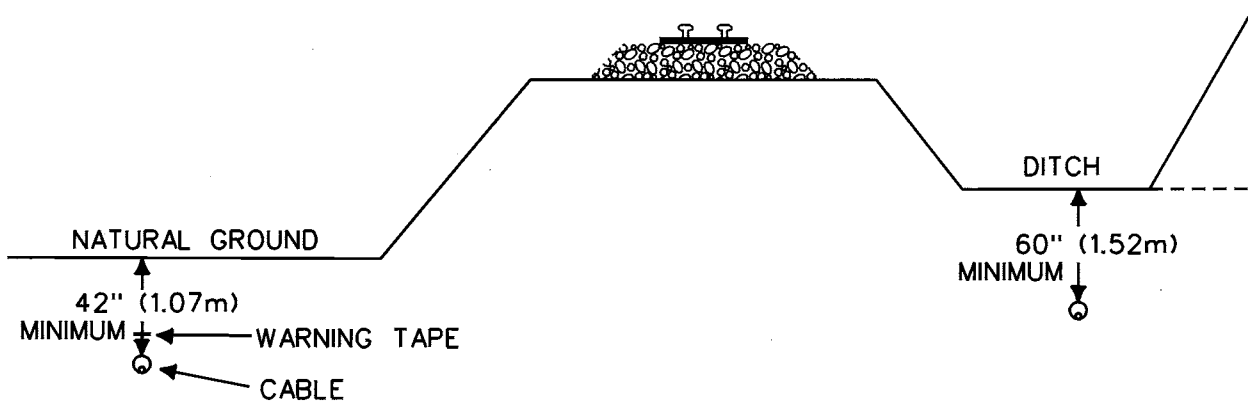

	Union Pacific RR
	EXHIBIT C
	BRIDGE DEFINITION
NO SCALE	PC-12-06-11

EFFECTIVE DATE: JANUARY 1, 2012



	Union Pacific RR
	EXHIBIT D
CABLE DEPTH AROUND CULVERTS AND DITCHES	
NO SCALE	PCP: 12-06-11

EFFECTIVE DATE: JANUARY 1, 2012

ALL UNDER TRACK BORES ARE TO BE AT 90 DEGREES
 WHEN USING A DIRECTIONAL BORE, AN ANGLE OF
 60 DEGREES OR GREATER CAN BE USED AT
 THE DISCRETION OF THE CC.

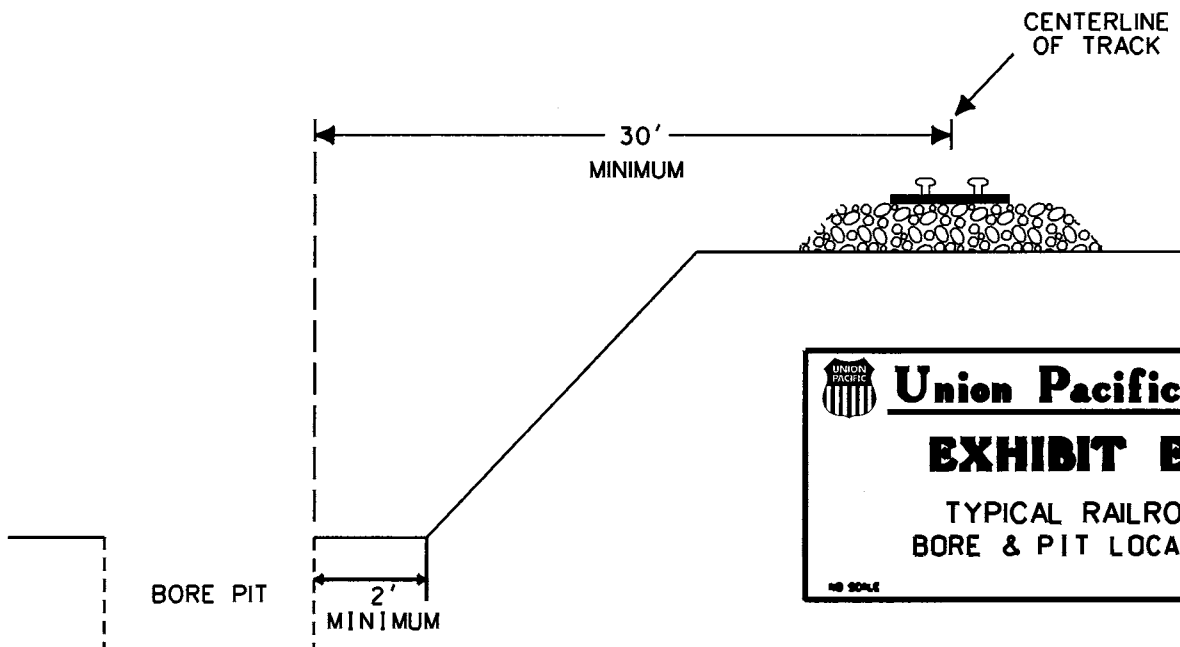
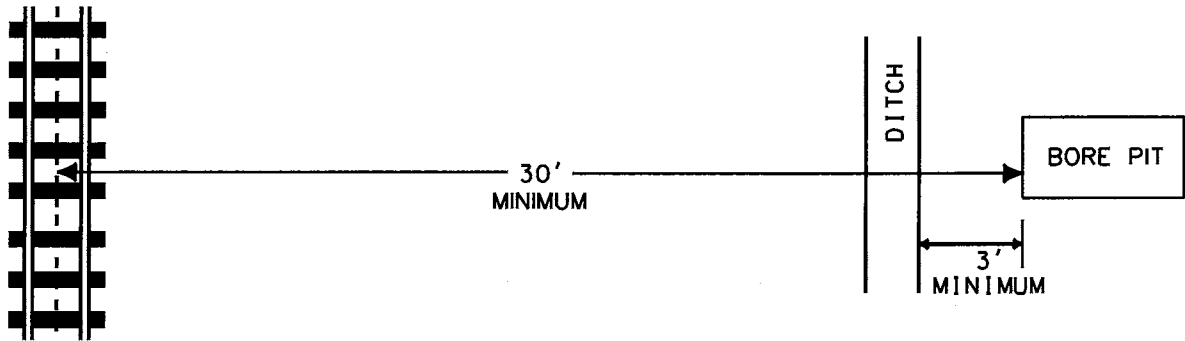
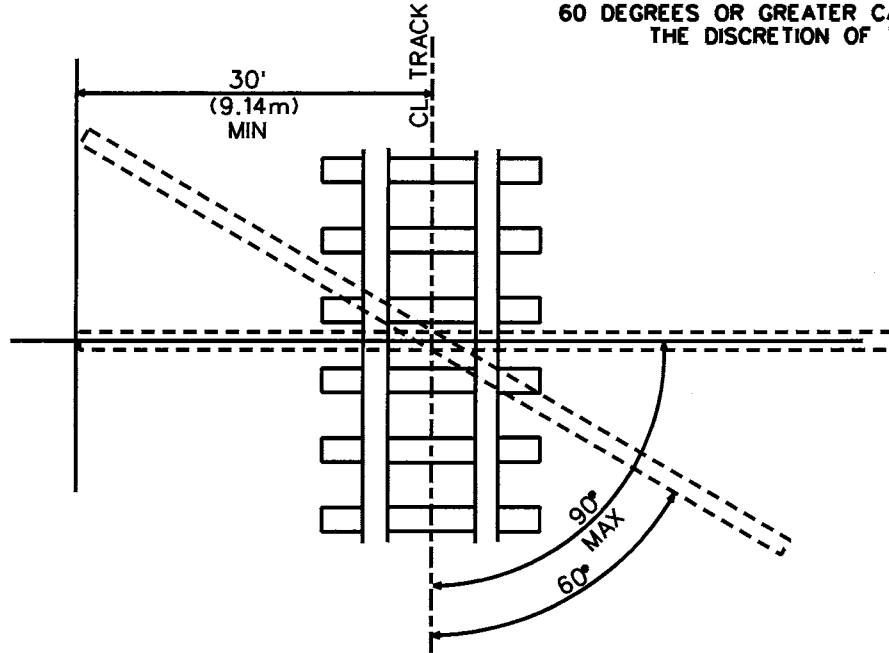

	Union Pacific RR
	EXHIBIT E
TYPICAL RAILROAD BORE & PIT LOCATION	
NO SCALE	PCF 12-85-12

EFFECTIVE: JANUARY 1, 2012

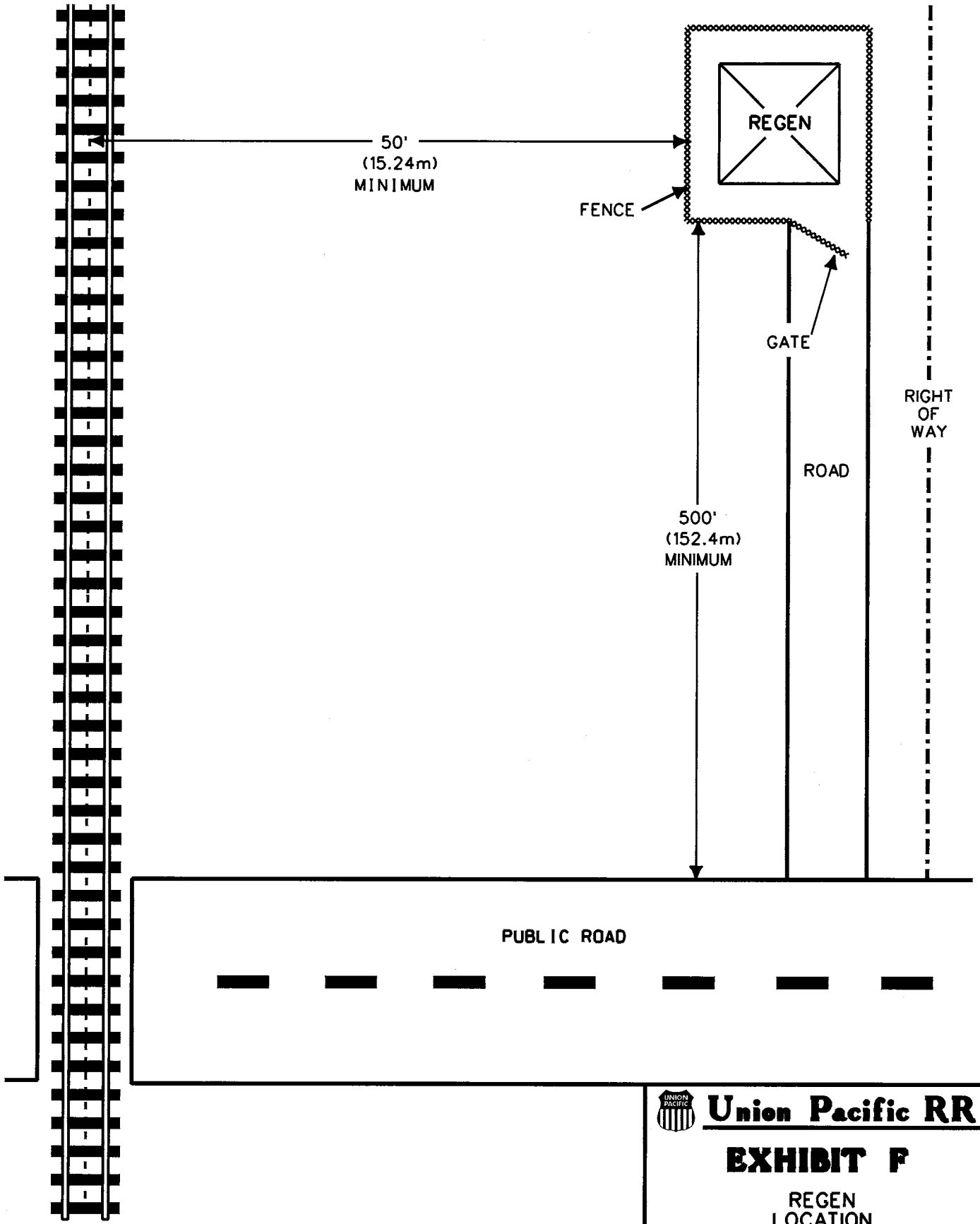

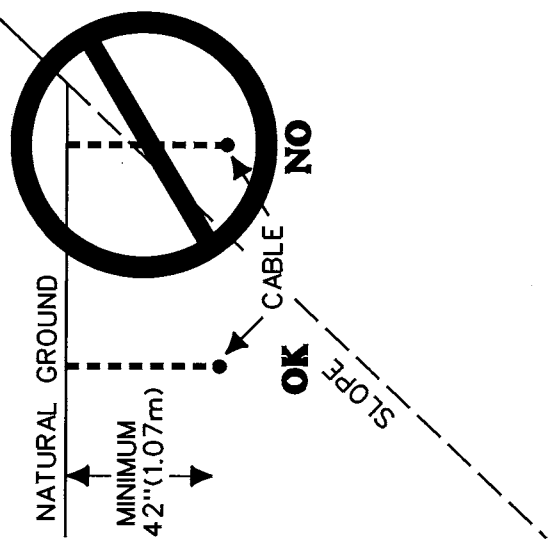
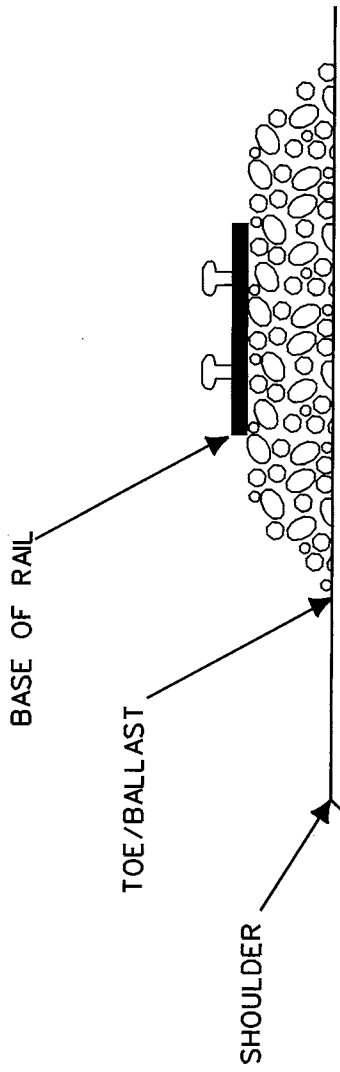

Union Pacific RR
EXHIBIT F
 REGEN
 LOCATION
NO SCALE UP:12-00-11

EFFECTIVE DATE: JANUARY 1, 2012



EFFECTIVE DATE: JANUARY 1, 2012

 **Union Pacific RR**
EXHIBIT G
 CONVENTIONAL
 FILL INSTALLATION

NO SCALE
 PCH 12-06-12

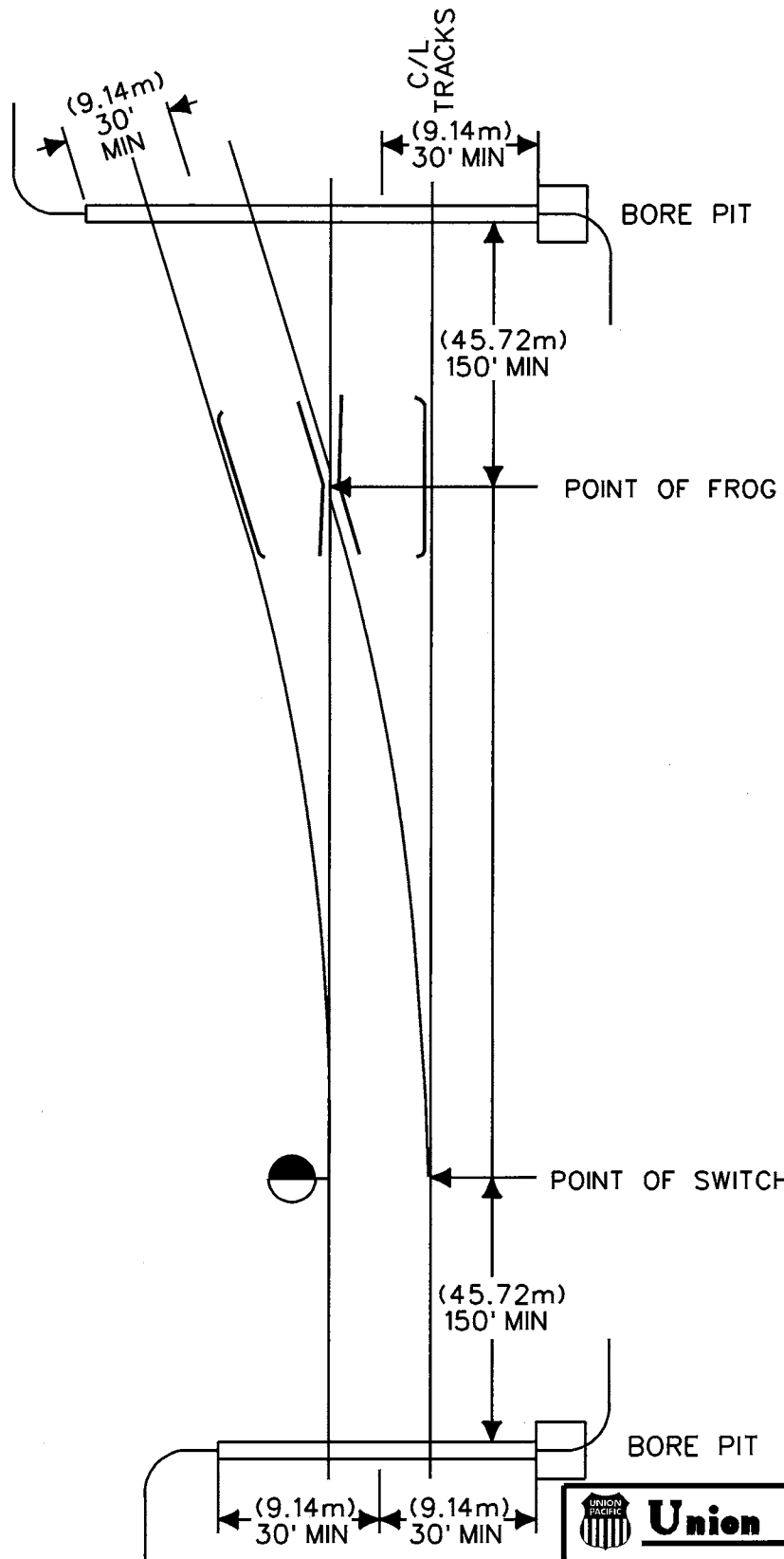

	Union Pacific RR
	EXHIBIT H
	STANDARD TURNOUT
<small>NO SCALE</small>	<small>UP: 12-86-12</small>

EFFECTIVE DATE: JANUARY 1, 2012

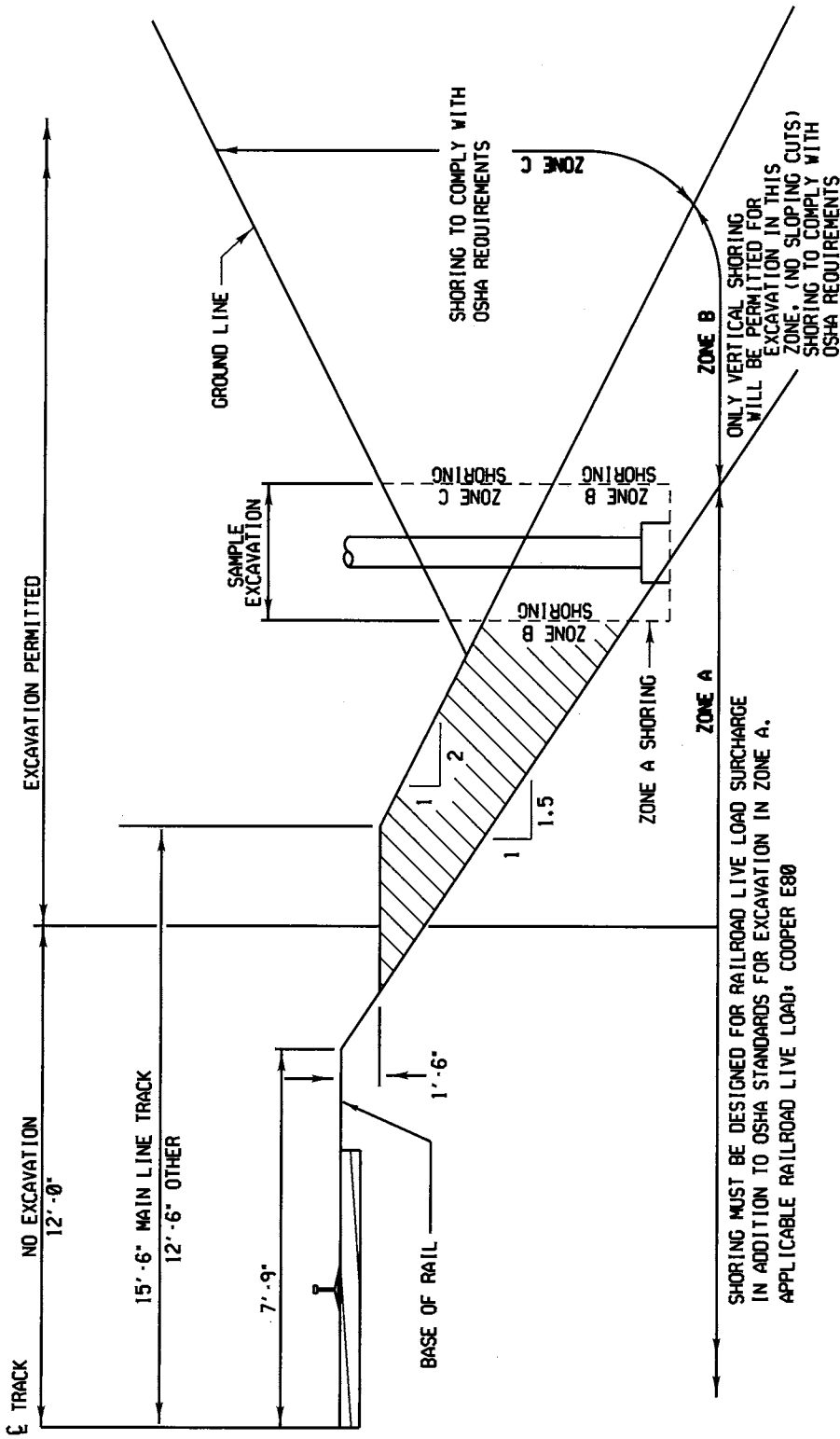

EFFECTIVE DATE: JANUARY 1, 2012

GENERAL NOTES:

ALL DIMENSIONS ARE MEASURED PERPENDICULAR TO CL OF TRACK
 PRIOR TO COMMENCING ANY WORK, THE CONTRACTOR SHALL SUBMIT FOR APPROVAL BY THE RAILROAD DETAILED PLANS INDICATING THE NATURE AND EXTENT OF THE TRACK PROTECTION SHORING PROPOSED. THE CONTRACTOR SHALL INSTALL THE TEMPORARY SHORING SYSTEM PER THE APPROVED PLANS. DESIGN OF THE TEMPORARY SHORING SYSTEM TO COMPLY WITH GUIDELINES FOR TEMPORARY SHORING

FOR EXCAVATIONS WHICH ENCRoACH INTO ZONE A OR B, SHORING PLANS SHALL BE ACCOMPANIED BY DESIGN CALCULATIONS. PLANS AND CALCULATIONS MUST BE SIGNED AND STAMPED BY A PROFESSIONAL ENGINEER REGISTERED IN THE STATE WHERE THE WORK WILL BE PERFORMED.

GENERAL EXCAVATION ZONES

EXHIBIT I

	UNION PACIFIC RAILROAD
LOCATION:	OFFICE OF CHIEF ENGINEER, DENVER
FACILITY:	SYSTEM STANDARD
DATE: 1/1/12	EXCAVATION ON RIGHT-OF-WAY
	GENERAL SHORING REQUIREMENTS

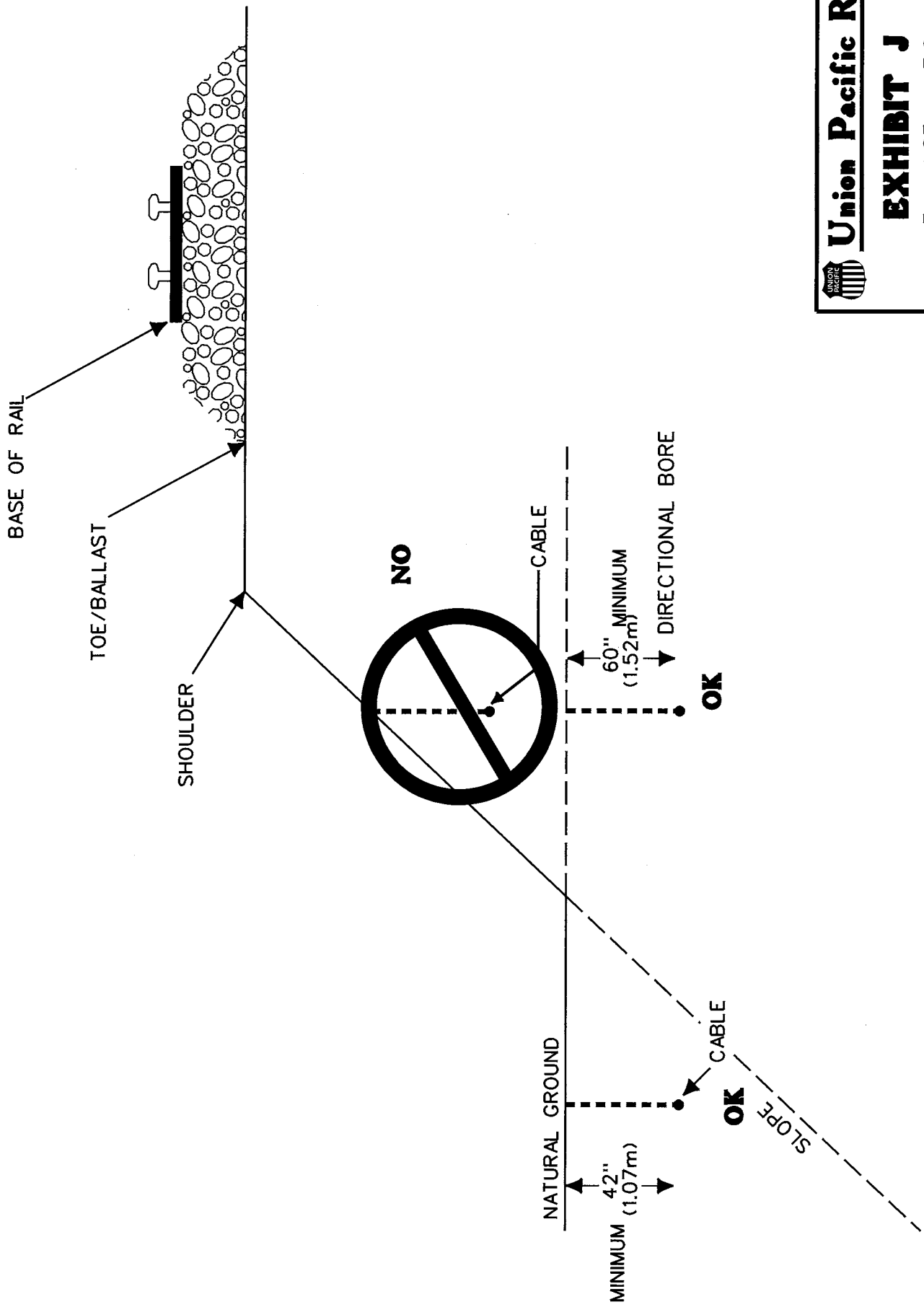

EFFECTIVE DATE: JANUARY 1, 2012

Union Pacific RR
EXHIBIT J
 FILL INSTALLATION
 DIRECTIONAL BORE

UP 5244
 PC-12-08-12

EQUIPMENT
NOT ALLOWED
WITHIN 5'
UNDISTURBED
AREA

5' (1.52m) MIN

42" (1.07m)

MINIMUM

OK

NO

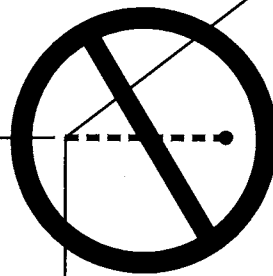

BASE OF RAIL

TOE/BALLAST

GROUND LINE

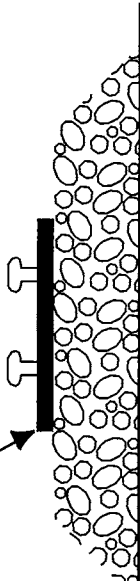

Union Pacific RR

EXHIBIT K

INSTALLATION
ON
TOP OF CUT

NO SCALE

POP 12-06-12

EFFECTIVE DATE: JANUARY 1, 2012

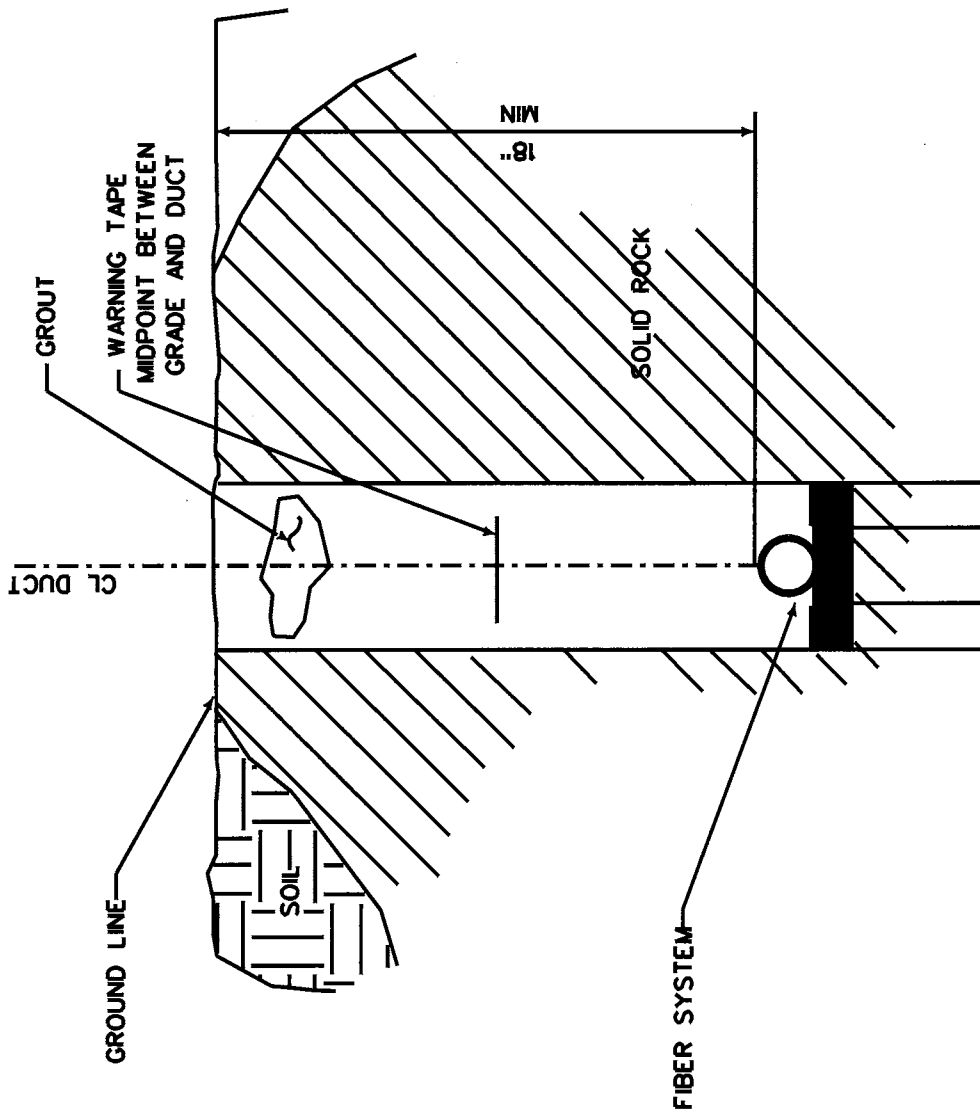

NOTES

UNTIL OR UNLESS THE CABLE SYSTEM IS AT THE DESIRED 42" DEPTH, THE ROCK TRENCH SHALL BE CUT AT A DEPTH OF 18" REGARDLESS OF GROUND LINES.

Union Pacific RR
EXHIBIT M
 ROCK TRENCH
UP 5244
REV. 12-08-12

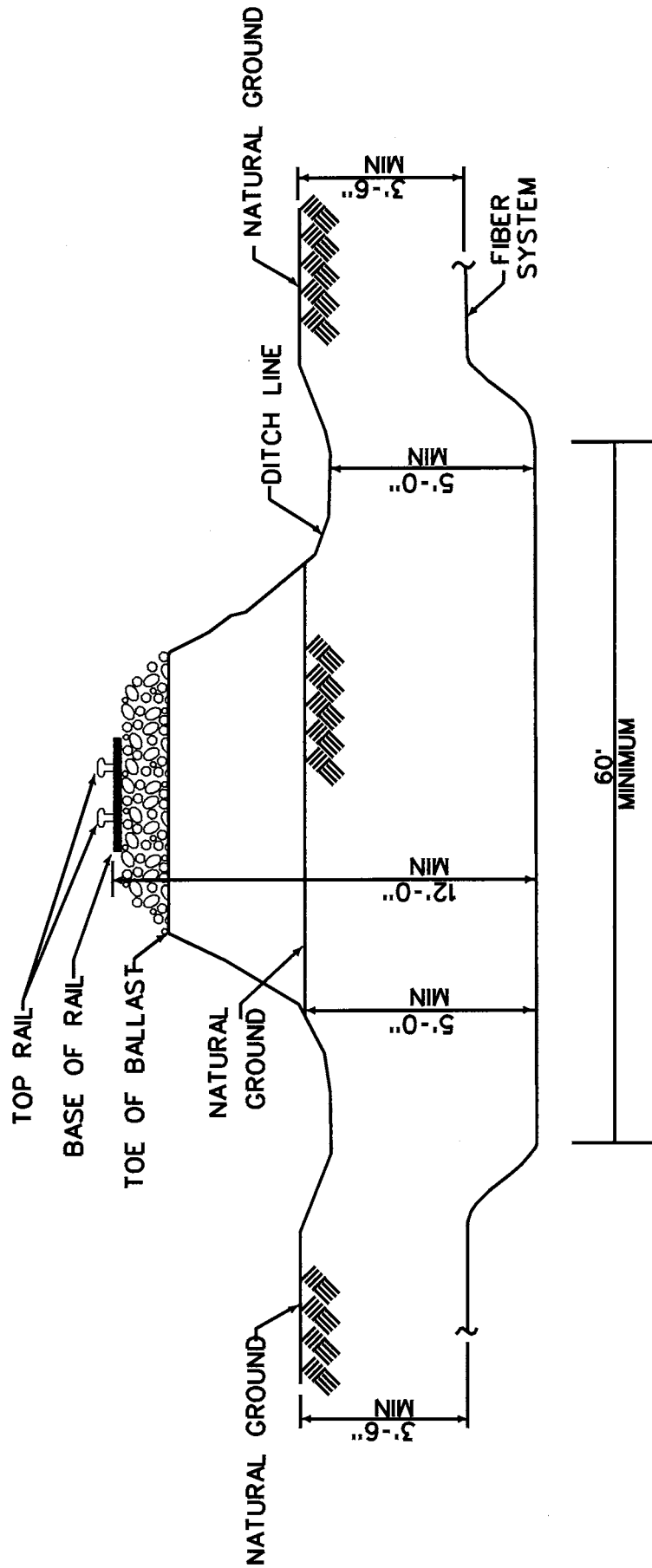

EFFECTIVE: JANUARY 1, 2012

Union Pacific RR
EXHIBIT N
 TYPICAL RAILROAD
 DIRECTIONAL BORE DEPTH
 UP 5045
 PC: 12-0-12

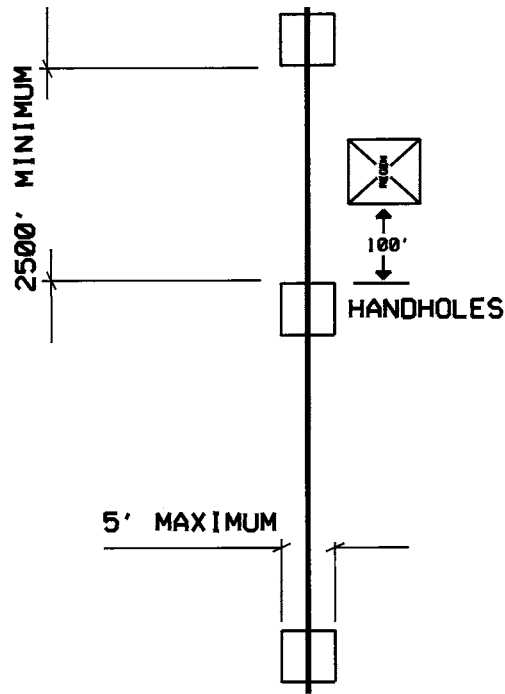

HANDHOLES MUST
HANDLE H-20 LOADING

RIGHT
OF
WAY



DO NOT CLUSTER!!
HANDHOLES MUST
RESIDE IN THE
RUNNING LINE

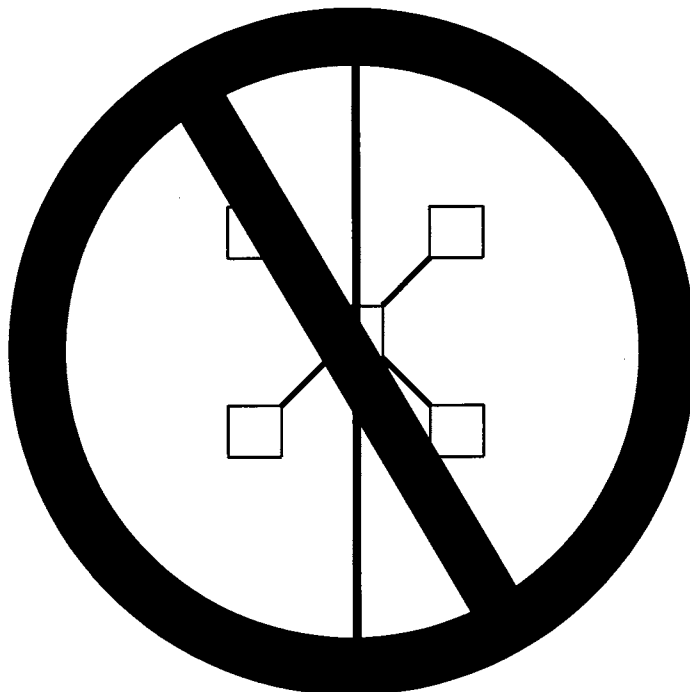

RIGHT
OF
WAY

 **Union Pacific RR**

EXHIBIT O

HANDHOLE
LOCATION

NO SCALE UPR 12-85-12

EFFECTIVE DATE: JANUARY 1, 2012

EXHIBIT P HOT WORK CHECKLIST

Date of Issue / Use: _____

Issued By: _____ Signature: _____

(Print Name Legibly)

Contractor Name: _____

Location or Work: _____

Task To Be Performed: _____

Specific Fire Hazards: _____

(Dried Grasses, Flammable Liquids, Combustible Materials i.e. wood, cardboard, etc.)

Hot Work IS: Any activity that creates live flame, molten slag, or sparks and includes: Metal cutting, welding, grinding, cut-off saw on metal or dry concrete, etc. Open warming fires are not allowed in any manner, shape or form.

NOTE: The location in which this Hot Work is to be performed shall be inspected before the Hot Work operations begin. The Hot Work shall not commence until all of the precautions noted below are in place.

FIRE SAFETY PRECAUTIONS

BEFORE THE WORK – All of the following precautions must be taken. Please initial the boxes at the left as completed.

- [] Cutting and/or welding equipment must be thoroughly inspected and found to be in good repair, free of damage or defect.
- [] Two fully charged, 20-lb minimum, multi-purpose dry chemical (ABC) portable fire extinguishers must be located at the point of operation.
- [] A means of contacting the Emergency Fire Services as noted with the Emergency Response Form must be available and accessible to the person(s) conducting the Hot Work operation.
- [] All equipment fueling activities and fuel storage, including portable fuel cans, must be located a minimum of 100 feet from the Hot Work location.
- [] 50 Gallons of water must be on hand, immediately available and reserved for firefighting purposes, along with one round nose shovel at least 46 inches in length for every employee involved in the Hot Work..
- [] Pre-Inspect the Hot Work area to remove, cover, or wet down any available combustible materials, i.e. dry grasses or brush, wood, RR ties, scrap, rubbish, etc. **(Step 1)**
- [] Spark shields must be used for the Hot Work.

DURING / AFTER THE WORK – The following precautions will be taken:

- [] A properly trained Fire Watch person must be assigned to watch for unwanted fires for a minimum of 30 minutes following all Hot Work activities. **There are no exceptions. (Step 2)**
- [] Fire watch persons must have immediate access to fully charged, 20-lb minimum, multi-purpose dry chemical (ABC) portable fire extinguisher, water based extinguisher, shovels and communication device all as noted above.

- The location where the Hot Work will take place has been **inspected before the start of the Hot Work operations** and all of the precautions listed above have been taken. **Responsible party must sign under Signature 1.**
- The work area and all adjacent areas have **been inspected 30 minutes after the Hot Work operation** has ceased for the day / period and found to be fire safe. **Responsible party to sign under Signature 2.**

Date: _____ Before: _____ After: _____

Signature 1 & Time
Pre-Work Inspection (Step 1)

Signature 2 & Time
Post-Work Inspection (Step 2)

EXHIBIT Q

The guidelines in this checklist are key factors often present at work sites; however, it is not an all-inclusive listing. Each excavation must fully comply with the most restrictive of applicable OSHA, State and/or Railroad requirements.

Trench Safety Inspection Checklist

Location: _____

Date: _____

Weather Conditions: _____

“Competent Person”: _____

Dimensions: Depth _____ Width _____ Length _____

Soil Type: Rock _____ Average Soil _____ Clay _____ Sand _____

Hazardous Conditions: Vibration _____ Wet Soil _____ Placement of Spoils _____

Additional Loads on Trench: Vehicles _____ Buildings _____ Other _____

Protection: Shoring _____ Ladder _____ Sloping _____ Benching _____

Fall Safety: Yes _____ No _____ (If six feet (6') or deeper, must have sides protected)

Confined Space Permit Required? Yes _____ No _____

Distance from Track: _____

Is Trench Safe to Enter? Yes _____ No _____

Notes: _____

EXHIBIT R

RAILROAD EMERGENCY RESPONSE FORM

LOCATION (RAILROAD SUBDIVISION AND MILEPOST) _____

CLOSEST CITY AND DIRECTIONS FROM IT TO THE JOB SITE (OR NEAREST CROSSING IF JOB SITE IS INACCESSIBLE FROM ROADWAY):

CLOSEST HOSPITAL AND DIRECTIONS FROM IT TO THE JOB SITE (OR NEAREST CROSSING IF JOB SITE IS INACCESSIBLE FROM ROADWAY):

NEAREST EMERGENCY SERVICES:

AMBULANCE: (_____) _____

FIRE: (_____) _____

POLICE (_____) _____

RAILROAD CONTACTS: _____

NAME _____ PHONE _____

PAGER _____ RADIO _____

NAME _____ PHONE _____

PAGER _____ RADIO _____

EMERGENCY NUMBERS:

GRADE CROSSING HOT LINE 1-800-848-8715

UPRR CBUD 1-800-336-9193

SPECIAL AGENT OR RMCC 1-888-877-7267 or 1-800-892-1283

1-888-UPRR-COP

Union Pacific Railroad

Fiber Optic Construction and Maintenance

ZERO TOLERANCE SAFETY PRACTICES

- All fiber optic workers must be safety trained and have a valid Union Pacific issued safety sticker on their hardhat.
- All personnel must wear a Union Pacific Railroad approved hard hat, safety glasses, highly visible orange outer wear that include reflective striping and safety-toe work boots.
- All running line changes must be approved by the Union Pacific Railroad Construction Coordinator. Flaggers are provided for protection from trains. Flaggers cannot approve running line changes or allow any deviation from the Union Pacific fiber optic safety policy.
- Before any train passes - stop all work, stand back well away from the track and watch the train pass.
- **WORKING ON OR AROUND TRACKS:**
 1. All work within or at 25' of centerline of track must be coordinated with the Construction Coordinator and shall utilize train protection. Such protection shall be provided by a watcher or flagger as governed by Rule 15.2.2-Protection for Non-Railroad Employees as covered by Railroad's System Special Instructions.
 2. All work outside 25' of centerline must be coordinated with the Construction Coordinator.
- Do not foul the track with any piece of equipment without a flagger and positive protection.
- Do not stand on the tracks or within 10' of the centerline of the track. The track is not an observation platform!
- Any excavation/hole less than 15' of centerline of track must be filled or properly shored prior to any train passing.
- No open excavation/holes left unattended.
- Do not disturb or foul the ballast at any time.
- Do not write on the rail or ties.
- All trenches must be shored conforming to OSHA specifications.
- All work is limited to 10 hours each day between sunup and sun down. It must be completely light during work hours.
- No work will be allowed on Railroad property on Sundays or Holidays.
- All Union Pacific Railroad fall protection instructions must be followed.
- All confined space and trench entry and/or occupation shall comply to OSHA Standard 29 C.F.R. 1910.146.
- **AT THE DISCRETION OF UNION PACIFIC RAILROAD, VIOLATION OF ANY OF THESE RULES WILL RESULT IN A MINIMUM OF THREE WORK DAYS OFF THE PROJECT, AND SUBJECT TO FURTHER DISCIPLINARY ACTIONS FROM FIBER OPTIC COMPANY.**