

RAIL WEIGHT	RAIL TYPE	RAIL DIMENSIONS								RAIL SECTION DESIGNATION (FOUND ON WEB OF RAIL)		
		HT	BW	HW	W	HD	FD	BD	E			
12	ASCE	2"	2"	1"	3/16"	5/16"	1 3/32"	11/32"	57/64"	-	-	-
15	ASCE	2 1/8"	2 3/8"	1 11/64"	3/32"	43/64"	1 23/64"	3/8"	1 1/16"	-	-	-
20	ASCE	2 3/8"	2 5/8"	1 11/32"	1/4"	23/32"	1 15/32"	7/16"	1 11/64"	-	-	-
25	ASCE	2 3/4"	2 3/4"	1 1/2"	19/64"	25/32"	1 31/64"	31/64"	1 55/64"	-	-	-
30	ASCE	3 1/8"	3 1/8"	1 11/16"	21/64"	7/8"	1 23/32"	1 7/32"	1 25/32"	-	-	-
35	ASCE	3 5/16"	3 5/16"	1 3/4"	23/64"	61/64"	1 25/32"	37/64"	1 15/32"	-	-	-
40	ASCE	3 1/2"	3 1/2"	1 7/8"	25/64"	1 1/16"	1 55/64"	5/8"	1 9/16"	-	-	-
45	ASCE	3 11/16"	3 11/16"	2"	27/64"	1 1/16"	1 31/32"	23/32"	1 41/64"	-	-	-
50	ASCE	3 7/8"	3 7/8"	2 1/8"	7/16"	1 1/8"	2 1/16"	1 1/16"	1 23/32"	-	-	-
55	ASCE	4 1/16"	4 1/16"	2 1/4"	15/32"	1 11/64"	2 11/64"	23/32"	1 103/128"	-	-	-
60	ASCE	4 1/4"	4 1/4"	2 3/8"	11/64"	1 7/32"	2 17/64"	45/64"	1 115/128"	6040	60 AS	603
60	MISC.	4 1/4"	4 3/16"	2 3/16"	1/2"	1 7/16"	2 1/8"	11/16"	1 3/4"	6051	-	-
65	ASCE	4 7/16"	4 7/16"	2 13/32"	1/2"	1 5/32"	2 3/8"	25/32"	1 31/32"	6540	65 AS	653
70	ASCE	4 5/8"	4 5/8"	2 7/16"	33/64"	1 11/32"	2 15/32"	13/16"	2 3/64"	7040	70 AS	701
75LB	ASCE	4 13/16"	4 13/16"	2 15/32"	17/32"	1 27/64"	2 35/64"	27/32"	2 15/128"	7540	75 AS	753
75LB	MO. PAC.	4 3/4"	4 3/4"	2 9/16"	9/16"	1 7/16"	2 13/32"	21/32"	2 5/64"	7550	75 MP	-
75LB	S. PAC.	4 15/16"	4 7/16"	2 7/16"	33/64"	1 5/8"	2 5/8"	15/16"	2 1/4"	7524	75 SP	757
80	ASCE	5"	5"	2 1/2"	35/64"	1 1/2"	2 5/8"	7/8"	2 3/16"	8040	80 AS	800
80	DUDLEY	5 1/8"	5"	2 21/32"	17/32"	1 1/2"	2 3/4"	7/8"	2 1/4"	8022	80 DY	-
85	ASCE	5 3/16"	5 3/16"	2 9/16"	9/16"	1 35/64"	2 3/4"	57/64"	2 11/64"	8540	85 AS	851
85	CAN. PAC.	5 1/8"	5"	2 1/2"	9/16"	1 7/16"	2 11/16"	1"	2 13/32"	8524	85 CP	-
85	CB&Q	5 3/16"	5 3/16"	2 21/32"	9/16"	1 35/64"	2 3/4"	57/64"	2 17/64"	8543	85 CB	852
85	MO. PAC.	5 7/32"	5 1/4"	2 15/32"	15/128"	1 3/4"	2 35/64"	55/64"	2 23/128"	8550	-	-
85	PS	5 1/8"	4 5/8"	2 1/2"	17/32"	1 21/32"	2 15/32"	1"	2 15/64"	8531	85 PS	-
85	PRR	5"	5"	2 9/16"	17/32"	1 3/4"	2 3/8"	7/8"	2 1/16"	8533	85 PR	-
85	SDD LINE	5 3/8"	4 7/8"	2 1/2"	9/16"	1 15/32"	2 29/32"	1"	2 29/64"	8520	-	-
90	ASCE	5 5/8"	5 3/8"	2 5/8"	9/16"	1 13/32"	2 55/64"	59/64"	2 45/128"	9040	90 AS	-
90	ARA-A	5 3/8"	5 1/8"	2 9/16"	9/16"	1 15/32"	3 5/32"	1"	2 37/64"	9020	90 RA	902
90	ARA-B	5 17/64"	4 49/64"	2 9/16"	9/16"	1 39/64"	2 5/8"	1 1/32"	2 11/32"	9030	90 RB	905
90	AT&SF	5 3/8"	5 3/16"	2 9/16"	9/16"	1 15/32"	3 5/32"	1"	2 27/64"	9021	90 SF	903
90	C&NW	5 17/32"	5 3/32"	2 1/2"	1/2"	1 13/32"	2 31/32"	1 1/32"	2 23/64"	9035	90 OM	-
90	D&RG	5 1/2"	5 1/8"	2 5/16"	9/16"	1 3/8"	2 7/8"	1"	2 3/8"	-	-	906
90	D&RG	5 1/2"	5 1/8"	2 5/16"	9/16"	1 3/8"	2 7/8"	1"	2 3/8"	-	-	906
90	GRT. NO.	5 3/8"	5"	2 5/8"	9/16"	1 15/32"	2 7/8"	1 1/32"	2 15/32"	9024	-	-
90	INTRBGH	5"	5"	2 7/8"	11/16"	1 25/32"	2 11/32"	7/8"	2 3/64"	9050	90RT	-
90	U. PAC.	5 3/4"	5 3/8"	2 3/4"	17/32"	1 1/2"	3 3/8"	7/8"	2 9/16"	9023	-	901
90	DUDLEY	5 1/2"	5"	2 21/32"	9/16"	1 1/2"	3 1/32"	31/32"	2 5/8"	-	90 DY	-

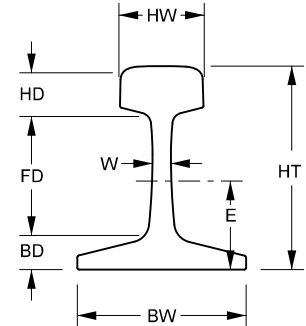

**RAIL DIMENSIONS**

NOTES:

**UNION PACIFIC RAILROAD  
ENGINEERING STANDARDS**

**RAIL IDENTIFICATION  
CHART**



ADOPTED: SEP. 21, 2020  
REVISED:  
FILE NO.: 0724

**STD DWG**

**0724**

PAGE 1 OF 2

STD DWG  
0724  
PAGE 1 OF 2

RAIL WEIGHT	RAIL TYPE	RAIL DIMENSIONS								RAIL SECTION DESIGNATION (FOUND ON WEB OF RAIL)		
		HT	BW	HW	W	HD	FD	BD	E			
100	ASCE	5 3/4"	5 3/4"	2 3/4"	9/16"	1 45/64"	3 5/64"	31/32"	2 65/128"	10040	100 AS	-
100	PS	5 11/16"	5"	2 43/64"	9/16"	1 13/16"	2 25/32"	1 3/32"	2 31/64"	10031	100 PS	-
100	PRR	5 1/2"	5 1/2"	2 13/16"	5/8"	1 7/8"	2 11/16"	15/16"	2 9/32"	10033	100 PR	-
100	ARA-A	6"	5 1/2"	2 3/4"	9/16"	1 9/16"	3 3/8"	1 1/16"	2 3/4"	10020	100 RA	1003
100	ARA-B	5 31/64"	5 4/64"	2 21/32"	9/16"	1 45/64"	2 55/64"	1 5/64"	2 65/128"	10030	100 RB	1002
100	AREA	6"	5 3/8"	2 11/16"	9/16"	1 21/32"	3 9/32"	1 1/16"	2 45/64"	10025	100 RE	10025
100	C&NW	5 45/64"	5 9/64"	2 9/16"	9/16"	1 39/64"	2 61/64"	1 9/64"	2 79/128"	10035	100-DM	-
100	GRT. NO.	5 3/4"	5"	2 3/4"	9/16"	1 5/8"	3"	1 1/8"	2 5/8"	10036	100 GN	-
100	INTRBGH	5 3/4"	5 1/4"	2 7/8"	9/16"	1 55/64"	3 5/64"	31/32"	2 65/128"	10005	100 RT	-
100	NY.NH&H	6"	5 1/2"	2 3/4"	15/32"	1 23/32"	3 11/32"	15/16"	2 39/64"	10034	100 NH	-
100	READING	5 3/8"	5 3/8"	2 23/32"	9/16"	1 45/64"	2 55/64"	1 1/16"	2 63/128"	10032	100 RG	-
101	DL&W	5 7/16"	5 3/8"	2 3/4"	5/8"	1 23/32"	2 11/16"	1 1/32"	2 3/8"	10133	101 DL	-
105	DL&W	6"	5 3/8"	2 3/4"	5/8"	1 23/32"	3 1/4"	1 3/32"	2 23/32"	10533	105 DL	-
105	DUDLEY	6"	5 1/2"	3"	5/8"	1 5/8"	3 11/32"	31/32"	2 43/64"	10524	105 DY	-
110	AREA	6 1/4"	5 1/2"	2 25/32"	19/32"	1 23/32"	3 13/32"	1 1/8"	2 57/64"	11025	110 RE	1100
110	GR. NO.	6 1/2"	5 1/2"	2 3/4"	19/32"	1 3/8"	3 3/4"	1 1/8"	3"	11036	110 GN	-
110	LE. VAL.	6"	5 1/2"	2 7/8"	19/32"	1 7/8"	3 1/16"	1 1/16"	2 15/32"	11033	110 LV	-
112	AREA	6 5/8"	5 1/2"	2 23/32"	19/32"	1 11/16"	3 13/16"	1 1/8"	2 7/8"	11228	112 RE	1121
112	TR.	6 3/4"	5 1/2"	2 1/2"	5/8"	1 3/4"	3 7/8"	1 1/8"	3 1/2"	11229	-	1122
113	SO. PAC.	6 13/16"	5 1/2"	2 11/16"	19/32"	1 7/8"	3 13/16"	1 1/8"	3 3/4"	-	-	1130
115	AREA	6 5/8"	5 1/2"	2 23/32"	5/8"	1 11/16"	3 15/16"	1 1/8"	2 7/8"	11525	115 RE	1150
115	DUDLEY	6 1/2"	5 1/2"	3"	5/8"	1 11/16"	3 3/4"	1 1/16"	3 3/8"	11522	115 DY	-
119	AREA	6 13/16"	5 1/2"	2 21/32"	5/8"	1 7/8"	3 13/16"	1 1/8"	2 7/8"	11937	119 RE	1190
127	DUDLEY	7"	6 1/4"	3"	21/32"	1 13/16"	4 5/32"	1 5/32"	3 1/8"	12723	127 DYM	-
130	PS	6 5/8"	5 1/2"	3"	11/16"	2"	3 13/32"	1 7/32"	2 3/4"	13031	130 PS	-
130	AREA	6 3/4"	6"	2 15/16"	21/32"	1 23/32"	3 11/16"	1 7/32"	3 1/16"	13025	130 RE	1300
131	AREA	7 1/8"	6"	3"	21/32"	1 3/4"	4 3/16"	1 5/16"	3 1/4"	13128	131 RE	1311
132	AREA	7 1/8"	6"	3"	21/32"	1 3/4"	4 3/16"	1 3/16"	3 3/32"	13228	132 RE	1321
133	AREA	7 1/16"	6"	3"	11/16"	1 15/16"	3 15/16"	1 3/16"	3"	13331	-	1330
136	LE. VAL.	7"	6 1/2"	2 15/16"	21/32"	1 7/8"	3 7/8"	1 1/4"	3 3/16"	13633	136 LV	-
136	AREA	7 5/16"	6"	2 15/16"	11/16"	1 15/16"	4 3/16"	1 3/16"	3 3/32"	13622	136 RE	13637
140	AREA	7 5/16"	6"	3"	3/4"	2 1/16"	4 1/16"	1 3/16"	3"	-	140 RE	-
140	PS	7 5/16"	6"	3"	3/4"	2 1/16"	4 1/16"	1 3/16"	3"	14031	140 PS	-
141	PS	7 7/16"	6"	3 1/16"	11/16"	2 5/32"	4 3/32"	1 3/16"	3 7/8"	-	141 PS	-
141	AB	7 7/16"	6"	3 1/16"	11/16"	2 5/32"	4 3/32"	1 3/16"	3 3/32"	-	141 AB	-
152	PS	8"	6 3/8"	3"	11/16"	1 27/32"	4 3/8"	1 3/32"	3 3/4"	15222	152 PS	-
155	PS	8"	6 3/8"	3"	3/4"	2 1/16"	4 23/32"	1 3/32"	3 7/8"	15531	155 PS	-

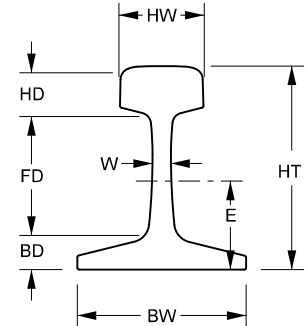

**RAIL DIMENSIONS**

NOTES:

<b>UNION PACIFIC RAILROAD ENGINEERING STANDARDS</b>	
<b>RAIL IDENTIFICATION CHART</b>	
	ADOPTED: SEP. 21, 2020 REVISED: FILE NO.: 0724
<b>STD DWG</b>	<b>0724</b>
PAGE 2 OF 2	

STD DWG  
 0724  
 PAGE 2 OF 2